



Vintage Strat® si



- 8 string Humbucker
- Humbucker Bass



Roswell® PICKUPS



Charlie Christian Style



Mini Lipstick Tube Pickup



6 string P-Bass® Pickup



Roswell
PICKUPS

Roswell has been trying to study constantly even today for the guitarists who seek for new and vintage tone all the time. Roswell would like to meet those who truly love music and musical instruments, and we are willing to help them in order to make musical world. Also, Roswell keeps invest our generous efforts to improve the instruments in the field of electronic technology which is able to make a new tone and sound.

W. Choi

Woo Sung Chorus Industries
Chairman and Co-Founder

Humbucker Pickups Lines

- | | | |
|-----------|--|---------------------|
| 3 | | HB HAF |
| | | HOT Link |
| | | MST |
| | | Vintage PAF |
| 5 | | LAF |
| | | LGA |
| | | LVS |
| | | LP90 |
| | | LGS |
| | | LPH |
| 7 | | Fanned Fret |
| | | LBD |
| | | Quarter Pound |
| 9 | | 7 Quarter Pound |
| | | HB81 |
| 11 | | HOT |
| | | FLT |
| | | Wide Range |
| | | 7LPN |
| 13 | | 7HB |
| | | 7HF |
| | | Active HB |
| 15 | | Active 7 string |
| | | MHB |
| | | LGM101 |
| | | RK |
| | | FTF94 |
| 17 | | FTR60 |
| | | FTS96 |
| | | FG |
| | | P90 Dog Ear |
| 19 | | P90 Dog Ear Stack |
| | | P90 Soap Bar |
| | | P90 Soap Bar Staple |
| | | JM-ADWH |
| | | JG-ADWH |
| 21 | | Mustang Bass |
| | | HCM |

Disclaimers: Fender®, Stratocaster®, Telecaster®, Jaguar®, and Mustang® are registered trademarks of Fender Musical Instruments. Gibson®, Les Paul®, P-90®, Flying V®, and Firebird® are registered trademarks of Gibson Guitar Corp. Music Man® is a registered trademark of Ernie Ball Corp. Rickshaw® is a registered trademark of Rickshaw International Corp. Wosung Chorus Industries is not affiliated with these companies.

Single Pickups Lines

- | | | |
|-----------|--|--------------------|
| 19 | | SC Modern |
| | | Strat Vintage® |
| 21 | | 61' Start® |
| | | 74' Start® |
| 23 | | Memphis Blue |
| | | QSTA |
| 25 | | SK52 |
| | | SV5 |
| 27 | | FSA |
| | | Custom Strat® |
| 29 | | ST Ceramic |
| | | SF Ceramic |
| 31 | | Stacked Singles |
| | | SM5S Passive |
| | | SM5G Active |
| 33 | | 7STA |
| | | VOX® Ceramic |
| 35 | | QS6 Ceramic |
| | | KS6 Alnico |
| 37 | | Quarter Pound Slim |
| | | TE Ceramic |
| 39 | | TEA |
| | | TE6 |
| 41 | | TEK |
| | | TEL |
| 43 | | SHR |
| | | SHS |
| 45 | | TEH |
| | | CHL-TF |
| 47 | | CHCB |
| | | TEA-B STP |
| 49 | | Hollow Tube |
| | | Solid Tube |
| 51 | | Mini Tube |
| | | Twin Tube |

icon key

RW RWRP	ZB ZEBRA	7S SEVEN	CV COVERD	FL FLAT TOP	SG STAGERO	LF LEFT HAND	TY TRIANGLE FOOT	MC MAT COILER	CP COOPER TAPE
-------------------	--------------------	--------------------	---------------------	-----------------------	----------------------	------------------------	----------------------------	-------------------------	--------------------------

Bass Pickups Lines

- | | | |
|-----------|--|---|
| 39 | | PBA |
| | | PBA20 |
| | | PBZ |
| | | DPM4 |
| | | QPA |
| | | PM4 |
| 41 | | PBA5 |
| | | DPM5 |
| 43 | | PBA6 |
| | | JBA |
| 45 | | JBA-CD |
| | | JM4 |
| 47 | | JMA4 |
| | | JV8 |
| 49 | | JSP4 |
| | | JBZ |
| 51 | | MJB |
| | | JA50 |
| 53 | | JB59 |
| | | JBXL |
| 55 | | JM5 |
| | | JHR |
| 57 | | MA4 |
| | | MA5 |
| 59 | | MA6 |
| | | MFR / SFR5 |
| 61 | | GB |
| | | BT |
| 63 | | BTZ Active |
| | | BTT |
| 65 | | BL |
| | | SW |
| 67 | | WB2 |
| | | Bass Custom |
| 69 | | MFPB |
| | | Dual Jazz Bass® |
| 71 | | Wood Cover |
| | | QJB / QJA |
| 73 | | Humbucker Bass |
| | | MHBB |
| 75 | | Vista Tone Bass |
| | | SWB |
| 77 | | RKB-CR |
| | | Mount Rings / Screws & Springs / Shield Plate / Wires |



HB HAF

The recipe for these pickups starts with a rough cast Alnico 5 magnet, plain enamel wire, and unique wind pattern. The bridge is a hotter-than-vintage 8.4K DC resistance and the neck is similarly beefy at 8.35K. Tonally, the rough cast magnets add warmth and balanced note-to-note clarity so everything sounds bigger. Warm and crystalline clean tones. Great for country, jazz, blues, funk, classic rock and heavy rock.

ZB 7S TY CP

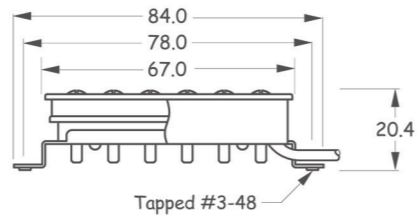
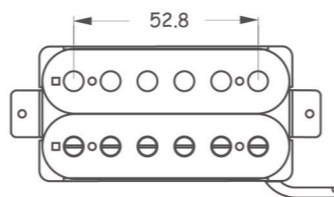
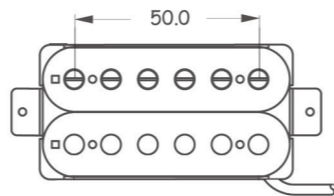
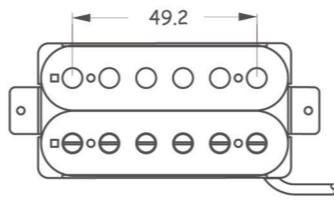
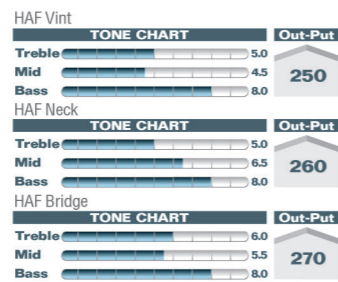

HAF-V
#32101
Vint
Alnico 5 Bar
4P Shield
8.3K
⌀49.2

HAF2-V
#33001
Vint
*Ceramic
4P Shield
8.3K
⌀49.2

HAF-N
#32102
Neck
Alnico 5 Bar
4P Shield
8.35K
⌀50.0

HAF2-N
#33002
Neck
*Ceramic
4P Shield
8.35K
⌀50.0

HAF-B
#32103
Bridge
Alnico 5 Bar
4P Shield
8.4K
⌀52.8

HAF2-B
#33003
Bridge
*Ceramic
4P Shield
8.4K
⌀52.8

MST Mat bobbins with black screws.

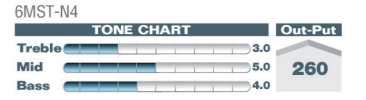

6MST-N4
#32371
Neck
Alnico 5 Bar
4P Shield
7.8K
⌀50.0

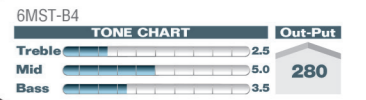

6MST-B4
#32373
Bridge
Ceramic
4P Shield
13.6K
⌀52.8

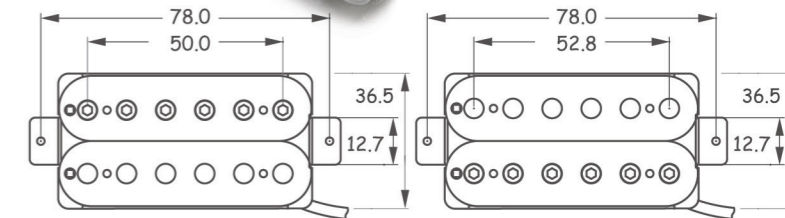

HOT LINK

High output tone for heavy rhythms and speed riffs. Used for classic rock, heavy rock and aggressive solo playing.

ZB 7S TY CP

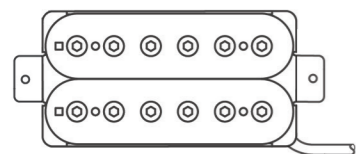
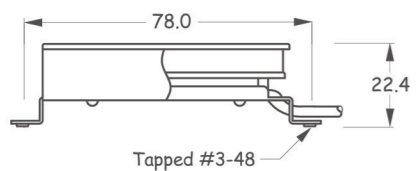
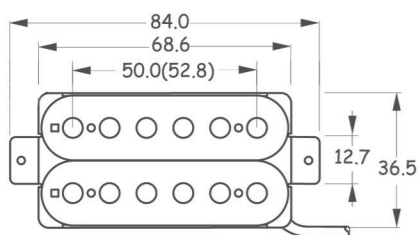

HBBC-N4
#31202
Neck
Ceramic Bar
4P Shield
8.6K

HBBC-B4
#31203
Bridge
Ceramic Bar
4P Shield
16.6K

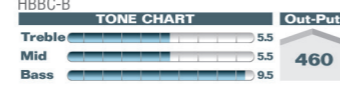
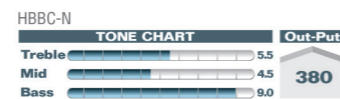

FN5-N
#31302
Neck
Ceramic Bar
4P Shield
8.6K

FN5-B
#31303
Bridge
Ceramic Bar
4P Shield
16.6K

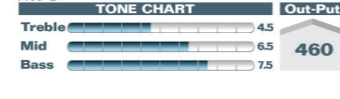
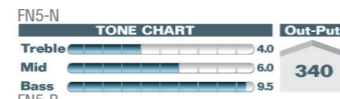

Vintage PAF

Versatile P.A.F type humbucker. Great for country, jazz, blues, funk, classic rock and heavy rock. Late-'50s, vintage-correct, humbucker sound. Warm and crystalline clean tones.

ZB 7S TY CP

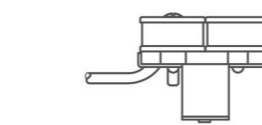
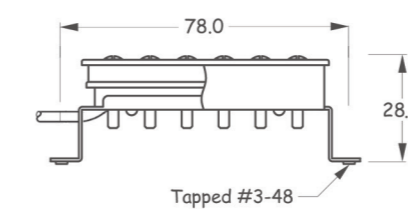
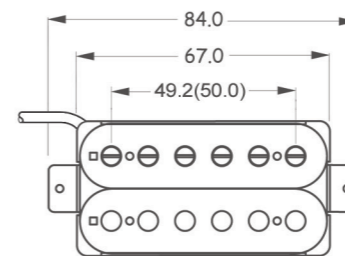

PV2-N
#33101
Neck
Alnico 2 Bar
4P Shield
Plain Enamel
8.3K
⌀49.2

PV2-B
#33103
Bridge
Alnico 2 Bar
4P Shield
Plain Enamel
8.4K
⌀49.2

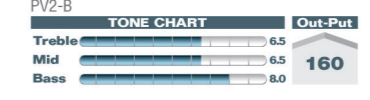
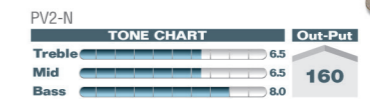

PV3-N
#33121
Neck
Alnico 2 Bar
4P Shield
Plain Enamel
8.3K
*⌀50.0

PV3-B
#33123
Bridge
Alnico 2 Bar
4P Shield
Plain Enamel
8.4K
*⌀50.0

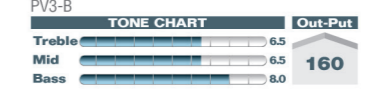
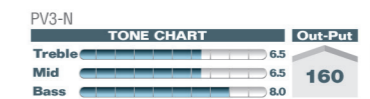



LAF

7S CV LF TY MC

Captures the airy top end, tight lows, balanced midrange, and complex overtones of the best original PAF pickups. In reviews it is consistently given high marks for its balanced frequency response. Unbalanced coils keep the bottom end tight for the amount of fullness the pickups have, overtones build after each note is played. Alnico 5 magnets in the neck & bridge are degaussed to specific levels.

LAF-N
#34102G
Neck
Alnico 5 Bar
1P Braided Shield
8.3K

LAF2-N
#34152G
Neck
*Ceramic
1P Braided Shield
8.3K

#34102C
Chrome

#34152C
Chrome

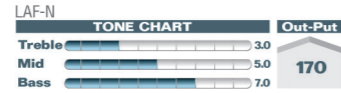

LAF-B
#34103G
Bridge
Alnico 5 Bar
1P Braided Shield
8.4K

LAF2-B
#34153G
Bridge
*Ceramic
1P Braided Shield
8.4K

#34103C
Chrome

#34153C
Chrome

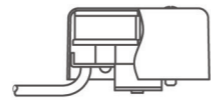
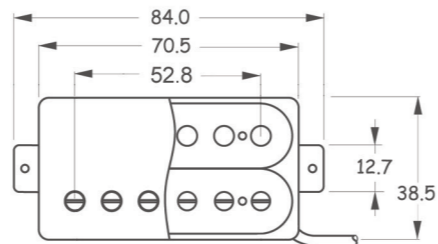
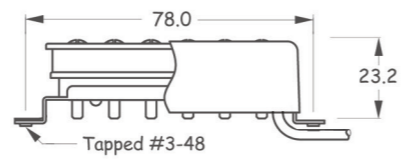
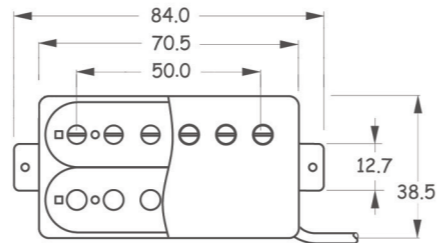
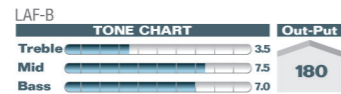

LGA

Single coil tones from a humbucker-size pickup. The output is similar to a P90, with enhanced clarity and chime.

LF TY MC

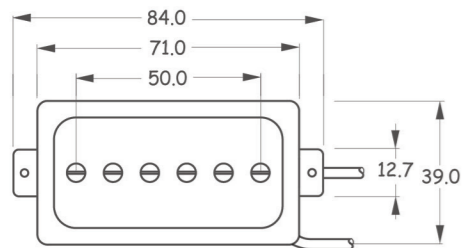

LGA90-N
#36102
Neck
Alnico 5 Bar
2P Shield
5.8K

LGA90-B
#36103
Bridge
Alnico 5 Bar
2P Shield
9.85K

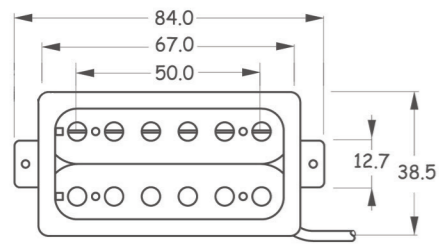
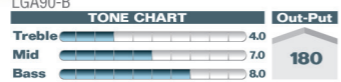
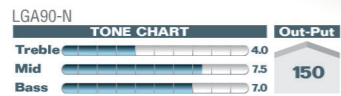

LGA-N
#36202
Neck
Alnico 5 Bar
1P Braided Shield
8.3K

LGA-B
#36203
Bridge
Alnico 5 Bar
1P Braided Shield
8.4K

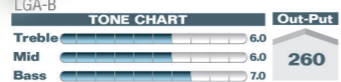
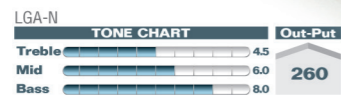

LVS

Ultra-authentic, Alnico2, P.A.F type humbucker. Great for country, jazz, blues and classic rock.

7S CV LF MC



LVS-N
#35102
Neck
Alnico 2 Bar
1P Braided Shield
8.3K

LVS2-N
#35152
Neck
*Ceramic
1P Braided Shield
8.3K

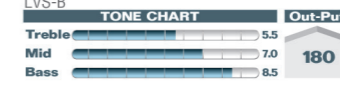
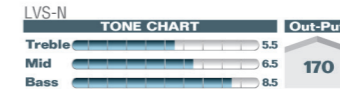

LVS-B
#35103
Bridge
Alnico 2 Bar
1P Braided Shield
8.4K

LVS2-B
#35153
Bridge
*Ceramic
1P Braided Shield
8.4K

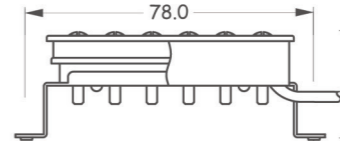
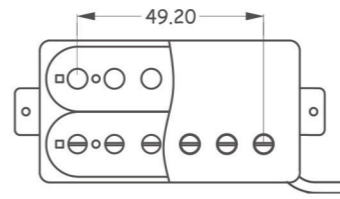

LP90

CV LF MC

Authentic P-90 sound in a humbucker retrofit size pickup. Recommended for country, jazz, blues, rockabilly, classic rock and heavy rock.

LP90-N
#36402
Neck
Alnico 5 Bar
2P Shield
5.8K

LP90-B
#36403
Bridge
Alnico 5 Bar
2P Shield
9.85K

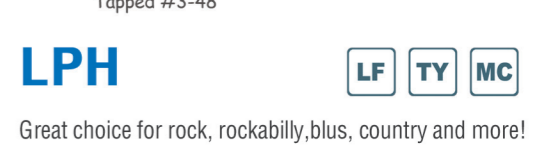
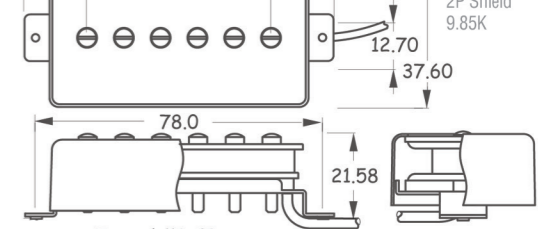
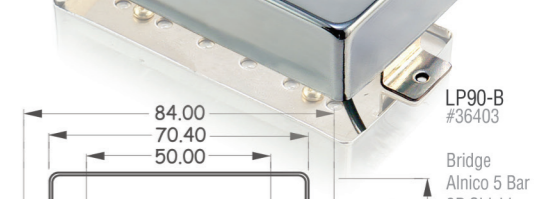

LGS

Hidden in a Humbucker housing you find our GRAND VINTAGE single coil for Strats.

LF TY MC

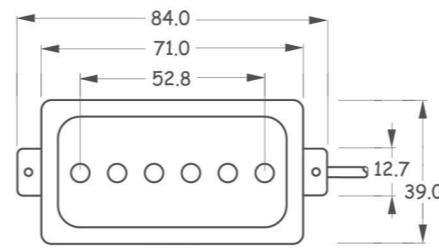

LGS10-N
#36212
Neck
Alnico 5 ROD
2P Shield
6.4K

LGS10-B
#36213
Bridge
Alnico 5 ROD
2P Shield
6.4K

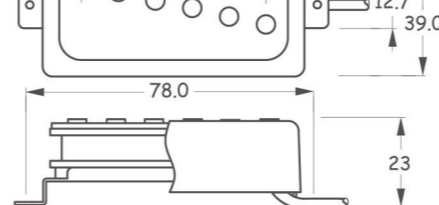
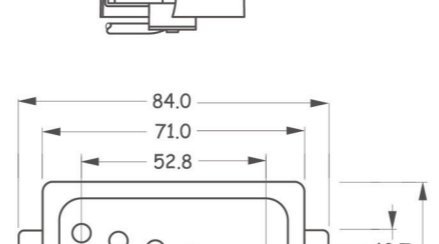

LPH

Great choice for rock, rockabilly, blues, country and more!

LF TY MC

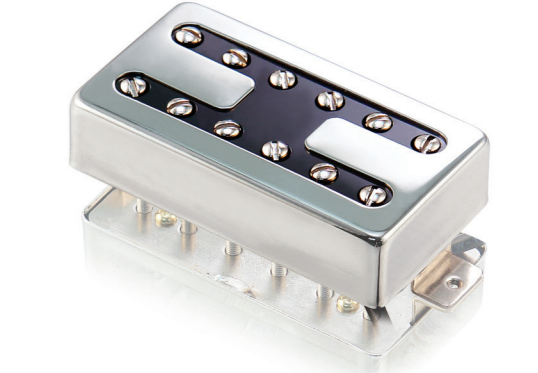

LPH-N
#36302
Neck
Alnico 5 Bar
4P Shield
8.6K
Ø50.0

LPH-B
#36303
Bridge
Alnico 5 Bar
4P Shield
16.6K
Ø52.8

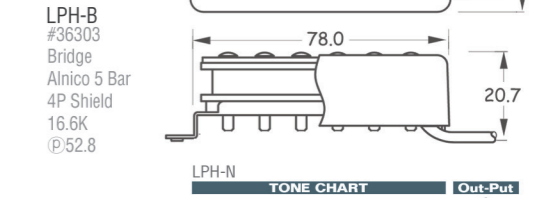

Fanned Fret

ZB 7S LF CP

These pickups are designed for Fanned Fret guitars. They are angled to suit fanned fret guitars which has a different scale length. These angled pickups will be more balanced sounding and further increase the smoother high strings and tighter low strings.



PFH6-N4
#42062
Neck
Alnico 5 Bar
4P Shield
8.6K
Ⓢ46.5

PFH6-N4 TONE CHART		Out-Put
Treble	4.0	320
Mid	5.0	
Bass	5.0	

PFH6-B4 TONE CHART		Out-Put
Treble	3.0	380
Mid	5.0	
Bass	4.0	

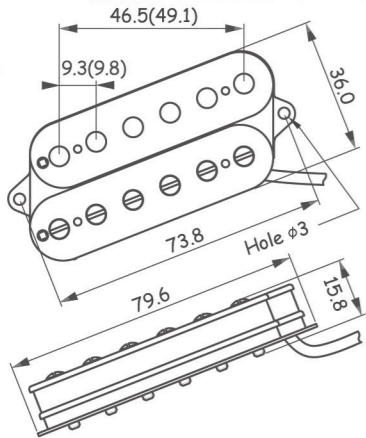

PFH7-N4
#42072
Neck
Alnico 5 Bar
4P Shield
8.8K

PFH7-N4 TONE CHART		Out-Put
Treble	4.0	280
Mid	5.0	
Bass	4.0	

PFH7-B4 TONE CHART		Out-Put
Treble	3.0	380
Mid	5.0	
Bass	4.5	

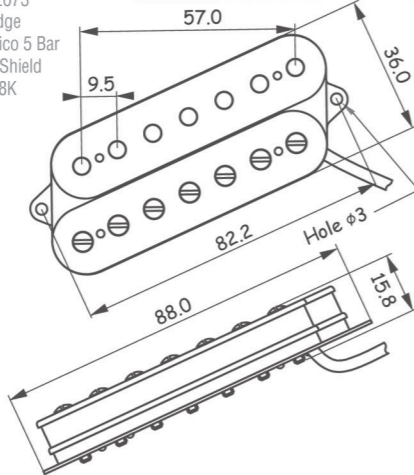

PFH8-N4
#42082
Neck
Alnico 5 Bar
4P Shield
9.6K

PFH8-N4 TONE CHART		Out-Put
Treble	2.5	260
Mid	4.5	
Bass	4.0	

PFH8-B4 TONE CHART		Out-Put
Treble	3.0	380
Mid	5.0	
Bass	4.0	

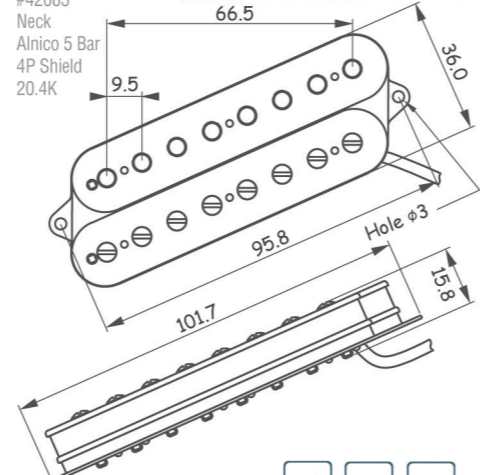

LBD

7S LF CP

The HB and HB Two/Tone are full-sized dual blade humbucker pickups designed for players who are looking for the maximum amount of tone, sensitivity and output, without being saddled with an inherently distorted or muddy-sounding humbucker. The HB provides incredible low-end clarity and overall high sustain characteristics that make it suitable for virtually any musical style, from blues to rock

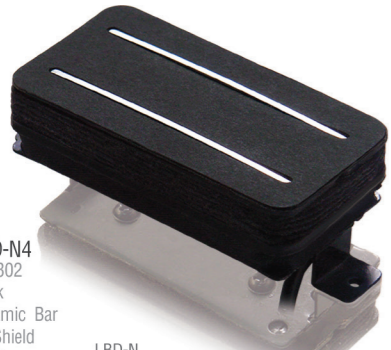

LBD-N4
#36802
Neck
Ceramic Bar
4P Shield
8.0K

LBD-N TONE CHART		Out-Put
Treble	5.5	240
Mid	6.5	
Bass	6.5	

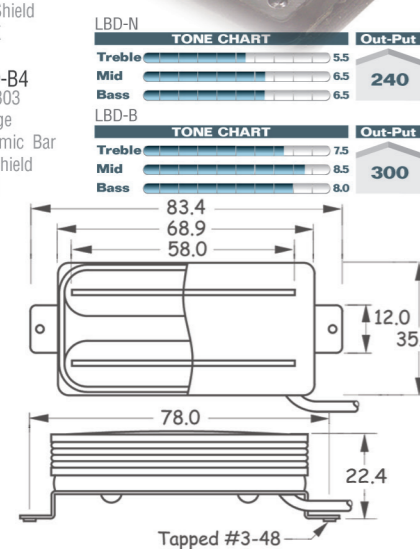

7LBD-N
#45202
Neck
Ceramic Bar
4P Shield
8.8K

7LBD-N TONE CHART		Out-Put
Treble	5.5	280
Mid	7.0	
Bass	7.5	

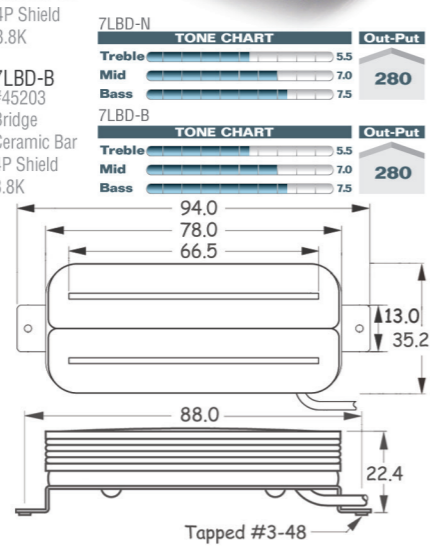

8LBD-N
#46602
Neck
Ceramic Bar
4P Shield
9.8K

8LBD-N TONE CHART		Out-Put
Treble	6.0	280
Mid	6.5	
Bass	7.0	

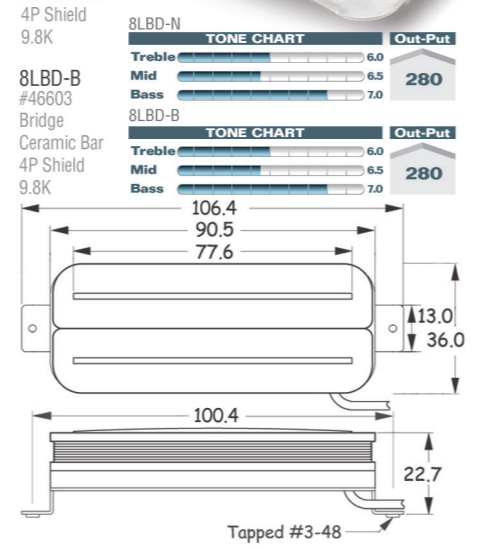

LBD-B4
#36803
Bridge
Ceramic Bar
4P Shield
9.2K

LBD-B TONE CHART		Out-Put
Treble	7.5	300
Mid	8.5	
Bass	8.0	

7LBD-B
#45203
Bridge
Ceramic Bar
4P Shield
8.8K

7LBD-B TONE CHART		Out-Put
Treble	5.5	280
Mid	7.0	
Bass	7.5	

Quarter Pound

7S LF CP

The quarter-inch diameter pole pieces expand the magnetic field and extend the frequency ranges for fat, full, punchy sound with tremendous mid-range presence maximum output.

KH6-50-N4		Out-Put
Treble	5.0	320
Mid	5.5	
Bass	8.0	

OH6		Out-Put
Treble	5.0	500
Mid	7.0	
Bass	8.0	

KH6-52.5-B4		Out-Put
Treble	4.5	300
Mid	6.0	
Bass	8.0	

MH6		Out-Put
Treble	4.5	460
Mid	6.5	
Bass	8.5	

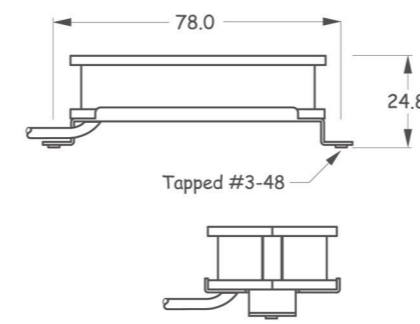
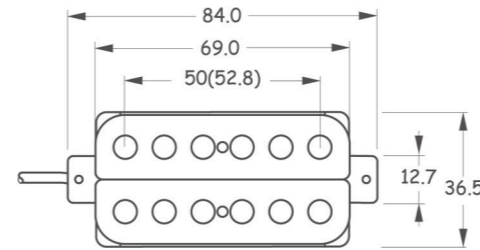

MH6-N
#36522
Neck
Ceramic Bar
4P Shield
10.18K
Ⓢ50.0

MH6-B
#36523
Bridge
Ceramic Bar
4P Shield
11.9K
Ⓢ52.8



KH6-50-N4
#36502
Neck
Alnico 2 ROD
4P Shield
10.18K
Ⓢ50.0

KH6-52.5-B4
#36503
Bridge
Alnico 2 ROD
4P Shield
11.9K
Ⓢ52.8

QH6-N
#36512
Neck
Ceramic Bar
4P Shield
10.18K
Ⓢ50.0

QH6-B
#36513
Bridge
Ceramic Bar
4P Shield
11.9K
Ⓢ52.8

7 Quarter Pound

The quarter-inch diameter pole pieces expand the magnetic field and extend the frequency ranges for fat, full, punchy sound with tremendous mid-range presence maximum output. Built exclusively for 7 string players.

KH7-N		Out-Put
Treble	4.5	280
Mid	6.0	
Bass	8.5	

KH7-B		Out-Put
Treble	4.0	300
Mid	5.5	
Bass	9.0	

7S LF CP

KH7-N
#45502
Neck
Alnico 5 ROD
4P Shield
11.8K

KH7-B
#45503
Bridge
Alnico 5 ROD
4P Shield
12.2K

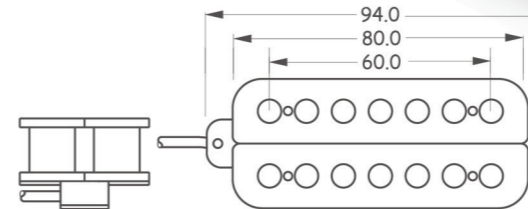
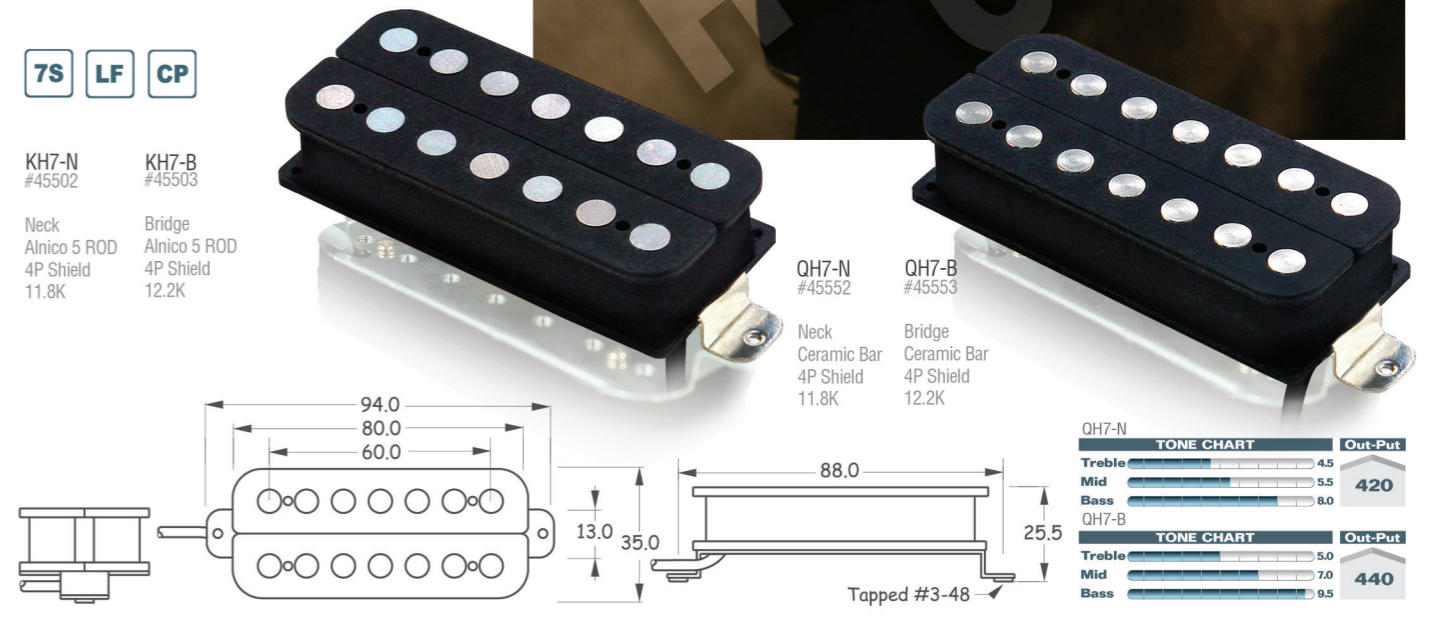

QH7-N
#45552
Neck
Ceramic Bar
4P Shield
11.8K

QH7-N TONE CHART		Out-Put
Treble	4.5	420
Mid	5.5	
Bass	8.0	

QH7-B
#45553
Bridge
Ceramic Bar
4P Shield
12.2K

QH7-B TONE CHART		Out-Put
Treble	5.0	440
Mid	7.0	
Bass	9.5	

HB81

ZB 7S CP

Built exclusively for 8 string players, the Sentient neck pickup is the perfect match for natural, complex is pushed to give a completely even tone. warmth and tight articulation. Relying on an alnico 5 magnet and medium strength coils, the blend of vintage PAF and modern tones sounds incredible in both clean and high gain settings. No frequency is pushed to give a completely even tone.

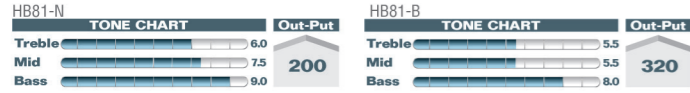

HB81-N
#46502

Neck
Alnico 5 Bar
4P Shield
9.6K

HB81-B
#46503

Bridge
Alnico 5 Bar
4P Shield
20.4K

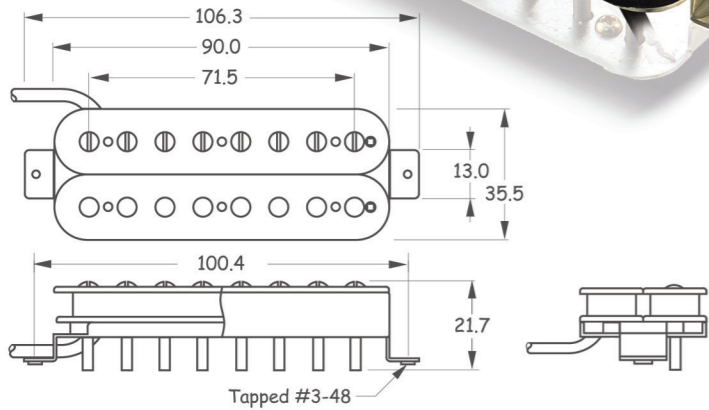

FLT

CV LF MC

These humbuckers feature two rows of adjustable polepiece, in bridge and neck position spacings. The neck pickup is warm and buttery, with a clear, present top end. The bridge pickup is fat and honky, with a rich low end and great clarity. Great choice for rock, rockabilly, blues, country and more!

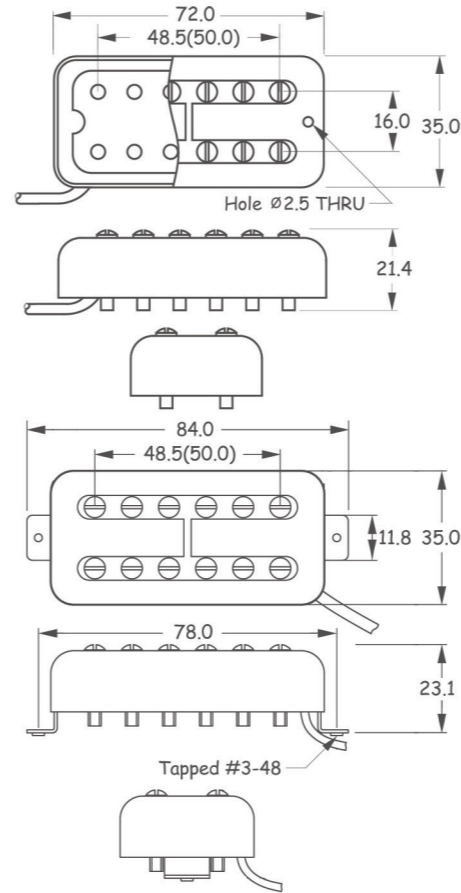

FLT-N-NI
#47012N

Neck
Alnico 2 Bar
1P Shield
4.0K
Ⓢ48.5

#47012C(Chrome)
#47012G(Gold)

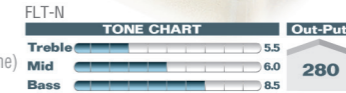

FLT-B-NI
#47013N

Bridge
Alnico 2 Bar
1P Shield
4.8K
Ⓢ50.0

#47013C(Chrome)
#47013G(Gold)

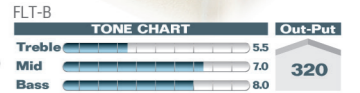

FLT2-N-NI
#47022N

Neck
Alnico 2 Bar
1P Shield
4.0K
Ⓢ48.5

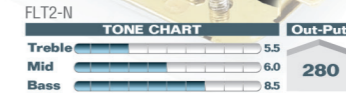

FLT2-B-NI
#47023N

Bridge
Alnico 2 Bar
1P Shield
4.8K
Ⓢ50.0



HOT

ZB CV LF TY MC CP

Ultra high output blade humbucker built for aggressive playing styles. Recommended for rock, metal, hard-hitting solos and other heavy rock styles.

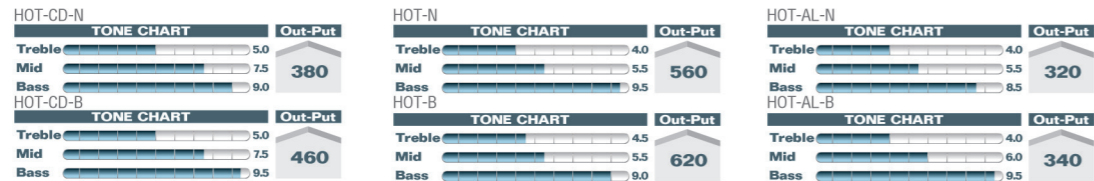

HOT-CD-N
#36602

Neck
Ceramic Bar
4P Shield
8.66K

HOT-CD-B
#36603

Bridge
Ceramic Bar
4P Shield
15.9K

HOT-N
#36612

Neck
Ceramic Bar
4P Shield
8.66K

HOT-B
#36613

Bridge
Ceramic Bar
4P Shield
15.9K

HOT-AL-N
#36622

Neck
Alnico 5 Bar
4P Shield
8.66K

HOT-AL-B
#36623

Bridge
Alnico 5 Bar
4P Shield
15.9K

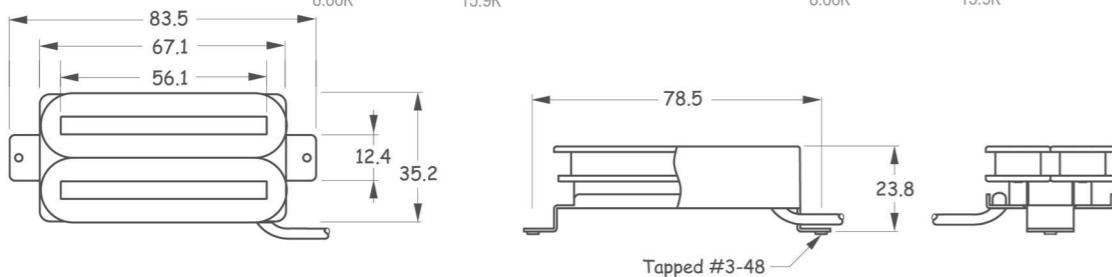

Wide Range

CV LF MC

They are fat and clear, with a nice top end sparkle. Great note bloom, with a vocal midrange that never sacrifices note definition. The originals had the same winding specs for the neck and bridge?ours vary a little for better volume and tone balance. Perfect for your Tele®Customs and Deluxes! Please note: This is a custom sized pickup. It is larger than a standard humbucker, and uses a different mounting pattern. It will not fit into a standard humbucker rout, or use standard humbucker mounting rings.

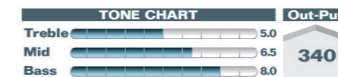

WDR10-CR
#47052

Neck & Bridge
Alnico 5 Bar
2P Shield
Plain Enamel
8.0K

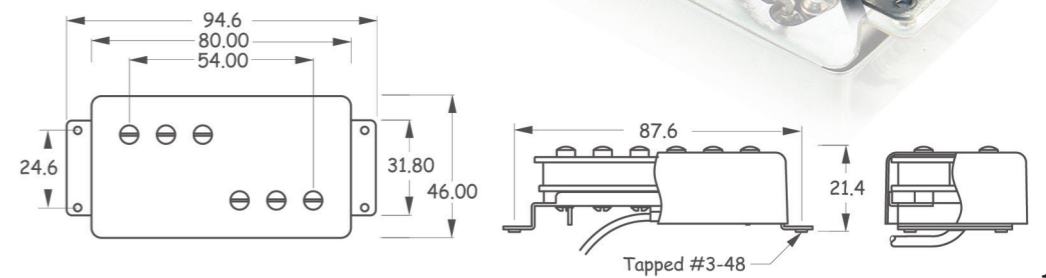



7LPN

ZB TY CP

Built exclusively for 7 string players, the Sentient neck pickup is the perfect neck pickup for natural, complex warmth and tight articulation. With an alnico 5 magnet and medium strength coils, the blend of vintage PAF and modern tones sounds excellent in both clean and high gain settings.

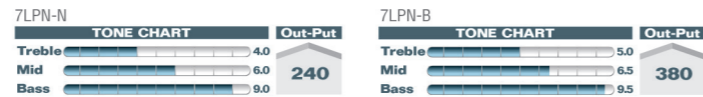

7LPN-N
#45102
Neck
Ceramic Bar
2P Shield
8.8K

7LPN-B
#45103
Bridge
Ceramic Bar
2P Shield
17.8K

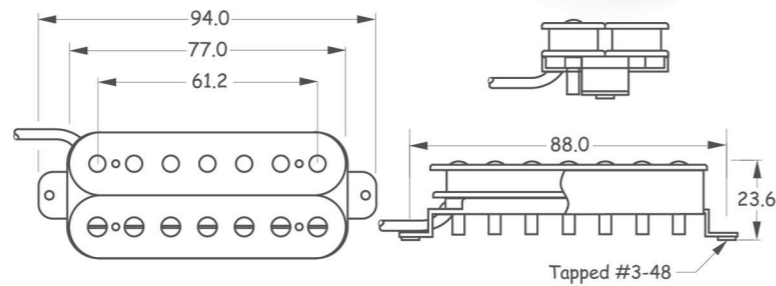

Active Humbuckers

Nine-volt active humbucker with classic voicing. Great for pop, country, blues, classic rock and heavy rock. The tone is full-bodied with a wide frequency response and rich sustain.



LZ51-N
#41002
Neck
Alnico 5 Bar
2P Shield
8.5K

LZ56-B
#41013
Bridge
Ceramic Bar
2P Shield
6.8K

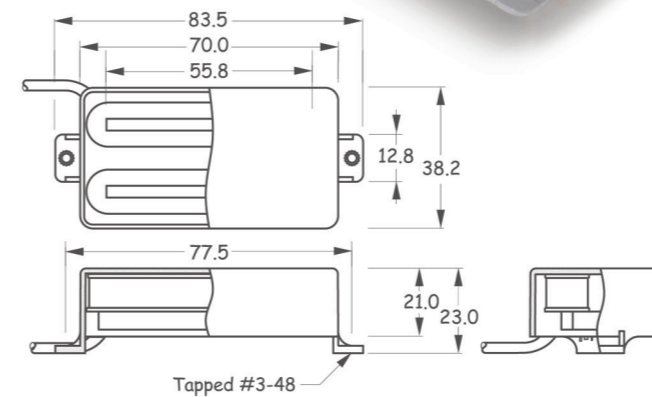

LZ61-N
#41062
Neck
Alnico 5 Bar
2P Shield
10.0K

LZ66-B
#41063
Bridge
Ceramic
2P Shield
8.0K

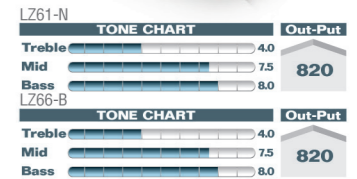
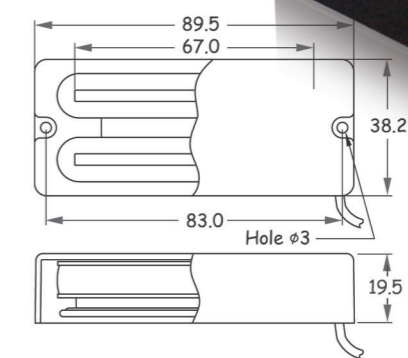

LZ71-N
#41072
Neck
Ceramic
2P Shield
5.8K

LZ76-B
#41073
Bridge
Ceramic
2P Shield
5.8K

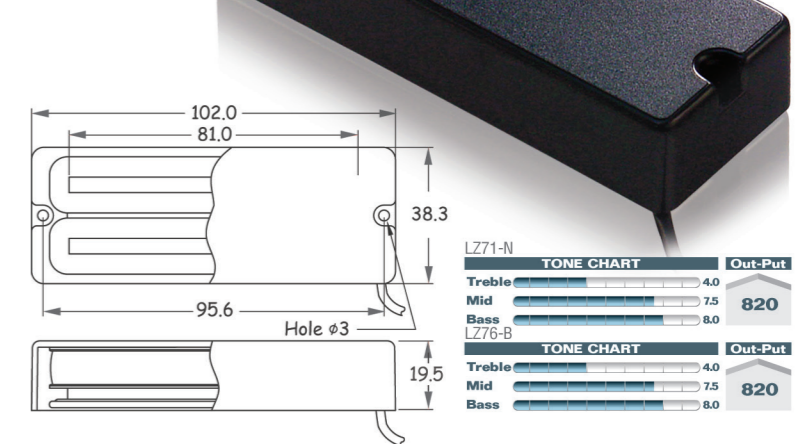

7HB Built exclusively for 7 string players

ZB TY CP

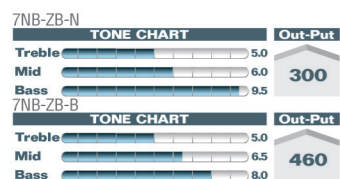

7HB-ZB-N
#45302
Neck
Ceramic Bar
4P Shield
8.8K

7HB-ZB-B
#45303
Bridge
Ceramic Bar
4P Shield
17.8K

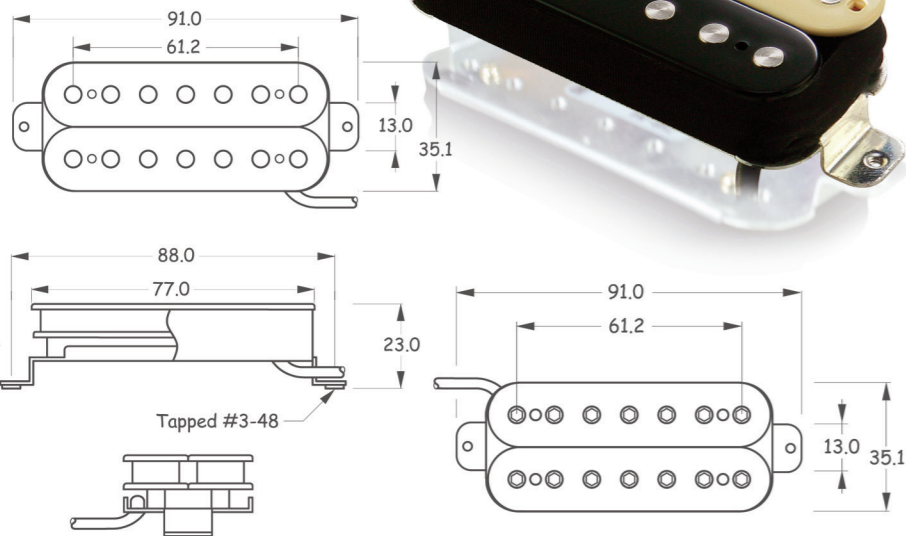

7HF

ZB TY CP

High output tone for heavy rhythms and speed riffs. Used for classic rock, heavy rock, hip hop, fusion and aggressive solo playing.



7HF-N
#45402

Neck
Ceramic Bar
4P Shield
8.8K

7HF-B
#45403

Bridge
Ceramic Bar
4P Shield
17.8K

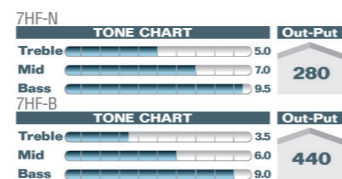

Active 7 string

Built exclusively for 7 string players. 9-VOLT active humbucker with classic voicing.

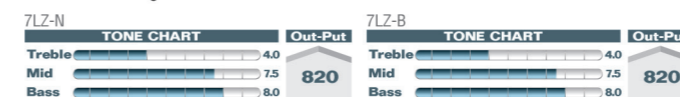

7LZ-N
#45602
Neck
Alnico 5 Bar
2P Shield
10.0K

7LZ-B
#45603
Bridge
Ceramic
2P Shield
8.0K

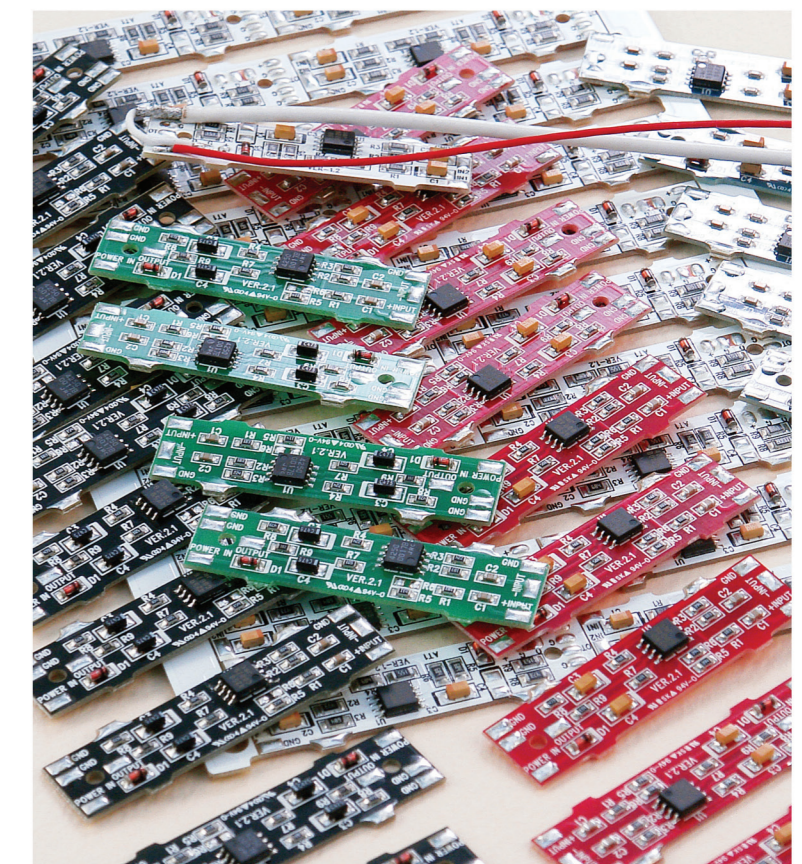
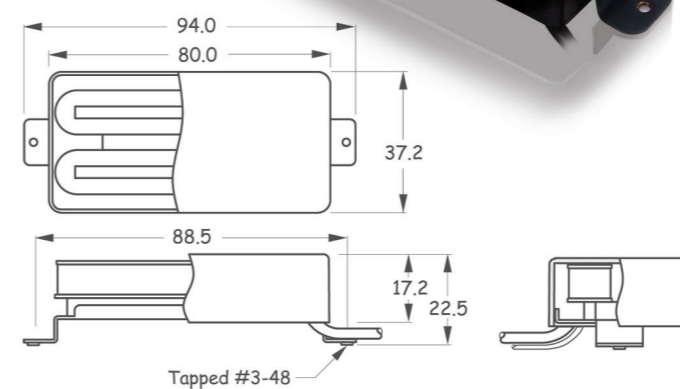
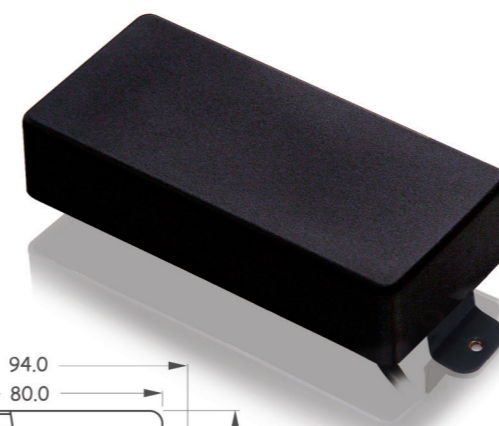



MHB

These mini humbuckers are wound with vintage specifications.

MHB62-N-CR #48202	MHB62-B-CR #48203
Neck Alnico 5 Bar 2P Shield 8.6K	Bridge Alnico 5 Bar 2P Shield 9.6K

MHB62-N	MHB62-B
TONE CHART	TONE CHART
Treble: 2.5	Treble: 2.0
Mid: 5.0	Mid: 6.5
Bass: 3.5	Bass: 5.0
Out-Put 200	Out-Put 240

MHB-N-CR #48102	MHB-B-CR #48103
Neck Alnico 5 Bar 1P Shield 8.6K	Bridge Alnico 5 Bar 1P Shield 9.6K

MHB-N	MHB-B
TONE CHART	TONE CHART
Treble: 2.5	Treble: 2.0
Mid: 5.0	Mid: 6.5
Bass: 3.5	Bass: 5.0
Out-Put 200	Out-Put 240

FTF94

Humbucker, with bracket for mounting at the end of the fingerboard for archtop guitar, no routing needed! A mellow mini humbucker for archtop jazz guitar. The brackets attach to the end of the fingerboard, suspending the pickup above the guitar top in the Johnny Smith style.

FTF94	FTF94-CR #48609
Alnico 5 Bar 1P Shield 12.6K	Alnico 5 Bar 1P Shield 12.6K

TONE CHART	Out-Put
Treble: 3.0	270
Mid: 5.0	
Bass: 3.5	

FTR60

Side mount floating pickups are perfect for use with traditional arch-top electric guitars. Its non-invasive mounting capabilities keep the guitar's acousting properties uninhibited.

FTR60-CR #48822	Alnico 5 Bar 1P Shield 12.6K
---------------------------	------------------------------------

TONE CHART	Out-Put
Treble: 3.0	270
Mid: 5.0	
Bass: 3.5	

FTR60	Alnico 5 Bar 1P Shield 12.6K
--------------	------------------------------------

TONE CHART	Out-Put
Treble: 3.0	270
Mid: 5.0	
Bass: 3.5	

FTS96

FTS96-GD
#48610G

Alnico 5 Bar
1P Shield
12.6K

FTS96	Alnico 5 Bar 1P Shield 12.6K
--------------	------------------------------------

TONE CHART	Out-Put
Treble: 3.0	270
Mid: 5.0	
Bass: 3.5	

LGM101

This mini humbucker with gold and metal foils has a more authentic vintage sound.

LGM101-N-CR #48402	LGM101-B-CR #48403
Neck Alnico 5 Bar 1P Shield 8.6K	Bridge Alnico 5 Bar 1P Shield 9.6K

LGM101-N	LGM101-B
TONE CHART	TONE CHART
Treble: 2.5	Treble: 2.0
Mid: 5.0	Mid: 6.5
Bass: 3.5	Bass: 5.0
Out-Put 200	Out-Put 240

RK

Rickenbacker® style vintage toaster electric guitar pickup. For neck, middle and bridge positions. Fits most models without modification.

RK-N-CR #48502	RK-B-CR #48503
Neck Ceramic Bar 1P Shield 8.6K	Bridge Ceramic Bar 1P Shield 8.6K

RK-N	RK-B
TONE CHART	TONE CHART
Treble: 3.0	Treble: 3.0
Mid: 6.0	Mid: 6.0
Bass: 8.0	Bass: 8.0
Out-Put 90	Out-Put 90

FG

Captures the big, brash sound of the great rockabilly hollow-body guitars with a touch of "snark" thrown in.

FG20	FG90
Alnico 5 Bar 1P Shield 4.2K	All Position Ceramic Bar 1P Shield 8.6K

TONE CHART	Out-Put
Treble: 5.5	100
Mid: 5.5	
Bass: 9.0	

TONE CHART	Out-Put
Treble: 3.0	340
Mid: 6.5	
Bass: 9.5	

P90® Dog Ear

Scatter wound pickup with de-gaussed Alnico 5 bar magnets. A fatter P-90® tone with smoother treble. Great for fat clean tone or harder driving rock with more grind. Neck and bridge will be equal, or bridge slightly hotter when playing single notes. Sold separately, or available in matched 2 or 3 piece sets. RWRP sets for hum-canceling operation. Single conductor, braided shield lead wire. The classic raw single-coil sound. These models carry on the raw sound of early rock, jazz and electric blues with two high quality Alnico 5 magnets.

RW CV CP



P90D-N-BLK
#26501
Neck
Alnico 5 Bar
1P Braided Shield
7.1K

P90D-B-BLK
#26503
Bridge
Alnico 5 Bar
1P Braided Shield
10.2K

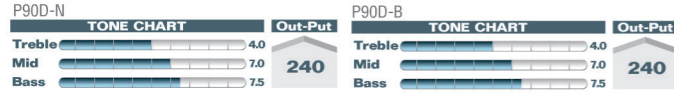
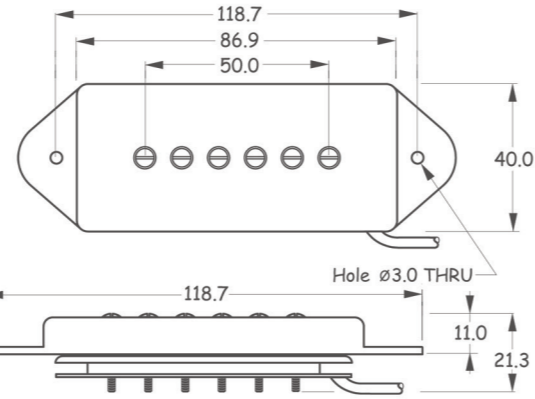

P90® Dog Ear Stack

P90 Dog Ear Stack pickup looks just like the original, but have two coils on top of one each other and wound to keep the natural tone without any excess noise.



P90D-STK-BLK
#26606
Alnico 5 Bar
4P Shield
17.8K

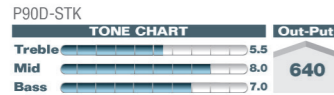
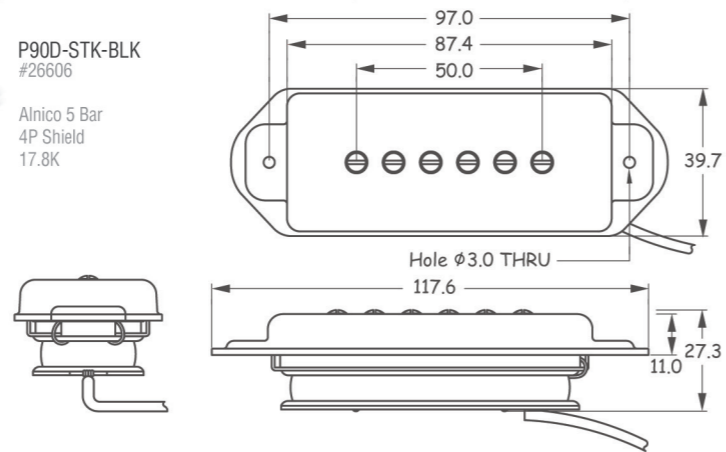

P90® Soap Bar

High output P-90® Excellent for modern country, heavy blues, classic rock, hard rock, punk, garage and metal.

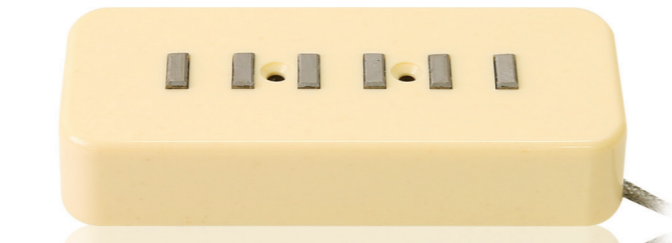

P90® Soap Bar Staple

P90® Soap Bar Staple pickup features beveled rectangular Alnico bar magnets. The tone is clean, smooth, and expressive.

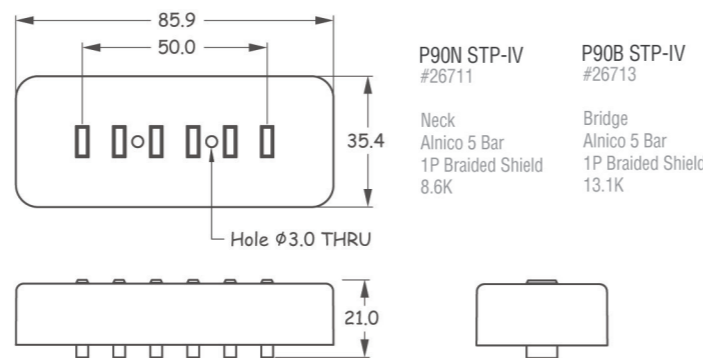
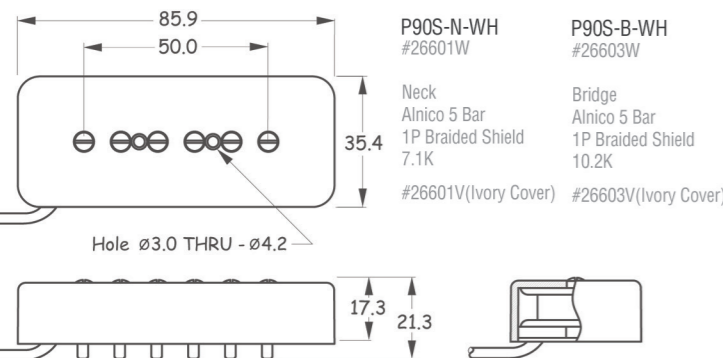

JM-ADWH

Jazzmaster® style for vintage correct single-coil pickup. Recommended for country, pop, surf, blues, jazz and classic rock.

RW CV SG CP

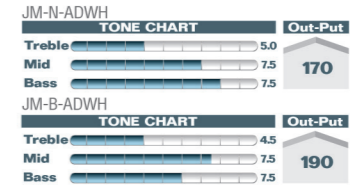
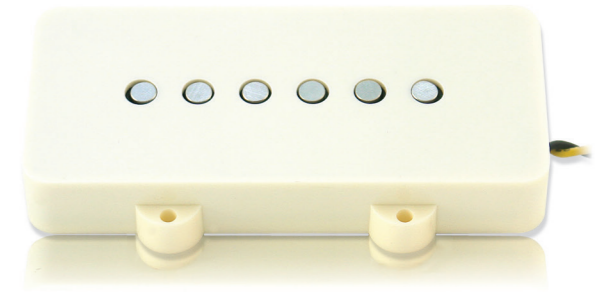
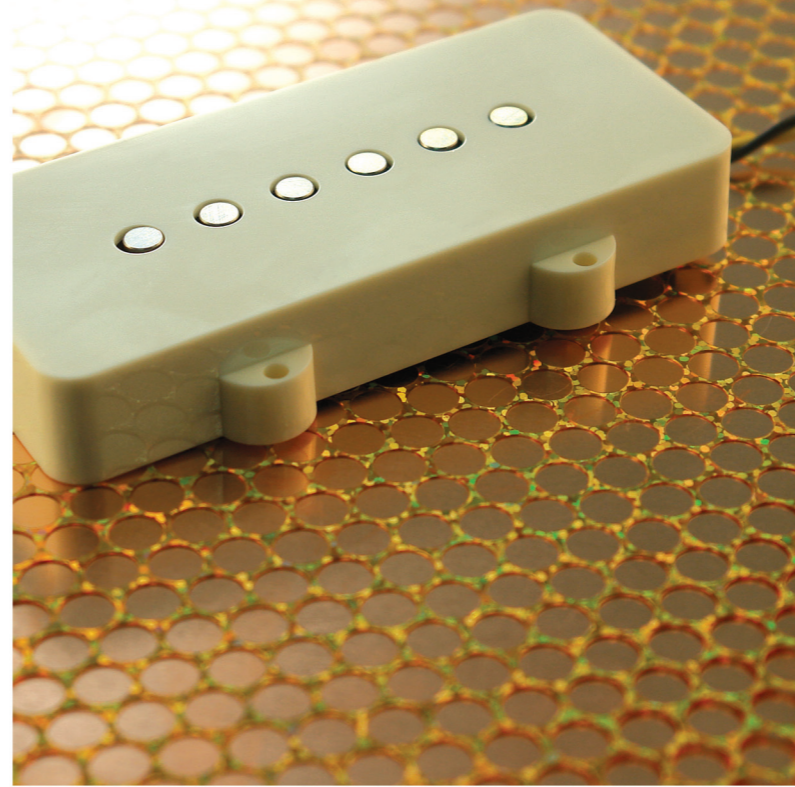

JM-N-ADWH
#26101
Neck
Alnico 5 Rod
Flex PVC
6.6K

JM-B-ADWH
#26102
Bridge
Alnico 5 Rod
Flex PVC
11.7K

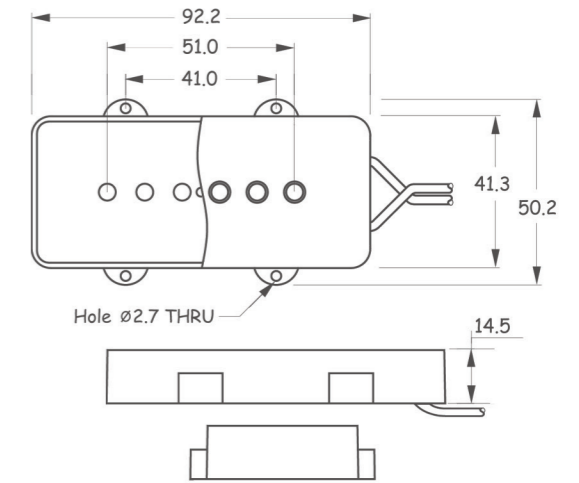

JG-ADWH

Jaguar® vintage style correct single-coil pickup. Recommended for country, pop, surf, rockably, blues and classic rock.

RW CV SG LF

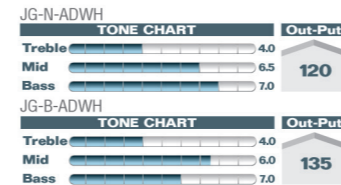
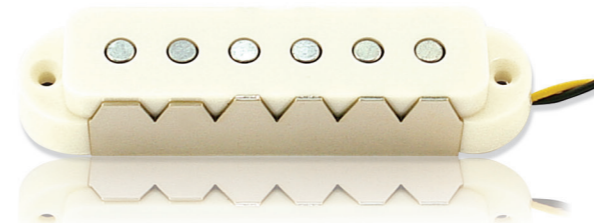

JG-N-ADWH
#26201
Neck
Alnico 5 Rod
Flex PVC
5.93K

JG-B-ADWH
#26202
Bridge
Alnico 5 Rod
Flex PVC
11.76K

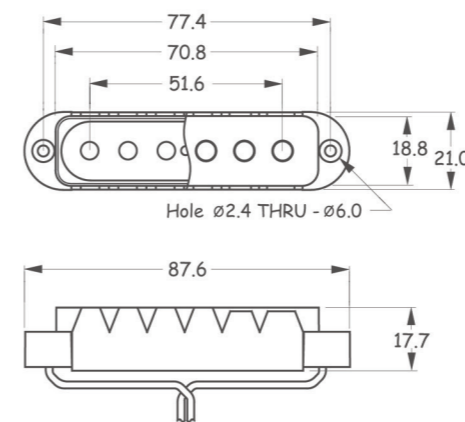

Mustang Bass®

Just like the original Mustang Bass® pickup. The Mustang Bass® pickups were of a different shape than those found on the P-bass® and came with rounded corners.

TONE CHART		Out-Put
Treble	3.5	140
Mid	8.0	
Bass	9.0	

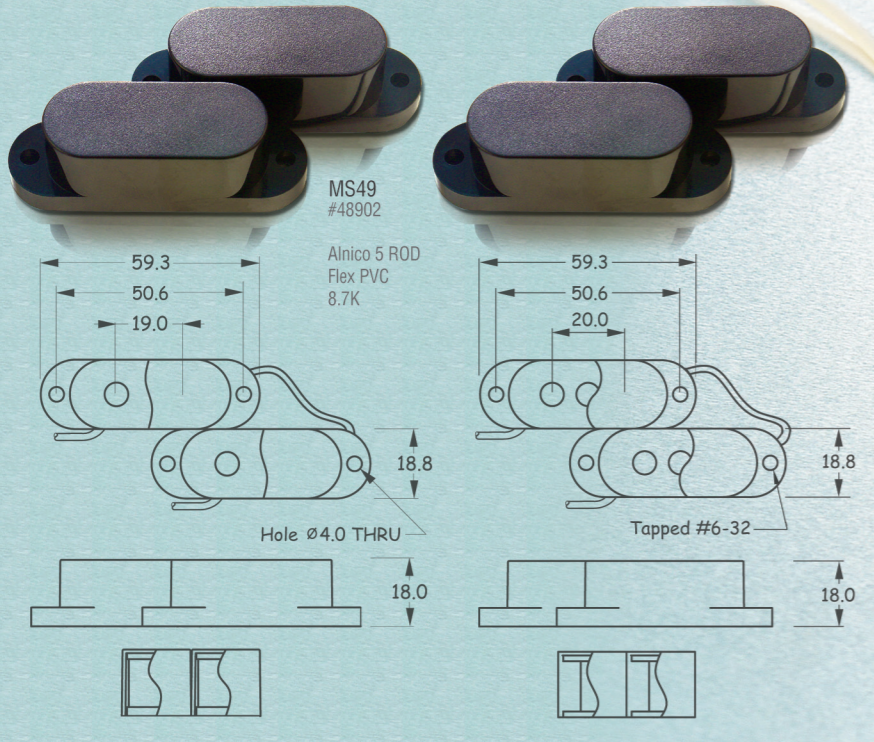

TONE CHART		Out-Put
Treble	3.5	220
Mid	5.0	
Bass	5.0	

TONE CHART		Out-Put
Treble	4.0	250
Mid	6.0	
Bass	5.0	

HCM

The tone of passive humbucker pickup is full-bodied with a wide frequency response and rich sustain.

HCM-N/B4 #41042

Ceramic Bar
4P Shield
8.6K

#41042R
Red

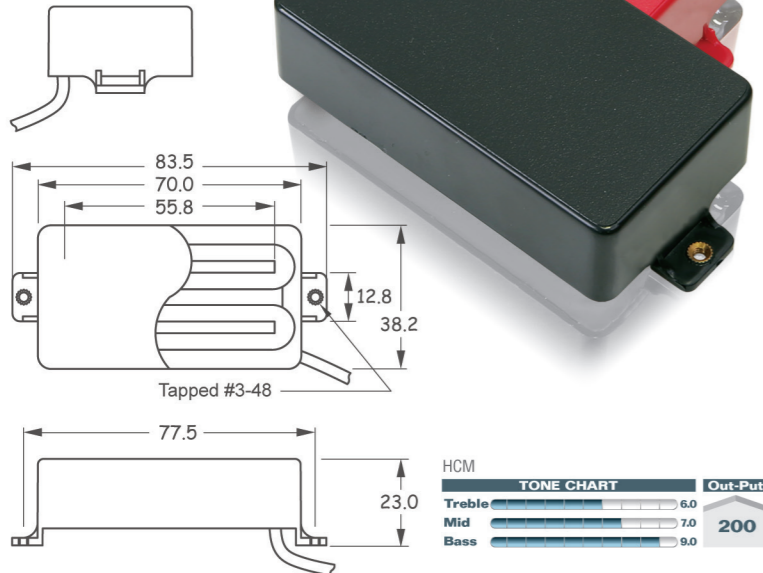

Custom Humbuckers

- Gold Pole and Screws
- Artificial Bobbins
- Trans Bobbins
- Pink Bobbins
- Red Bobbins
- Invader 6 & 7 string
- Aged Cover
- Natural Cover
- Pearl Black Cover
- Mat Black Cover
- Chrome Cover 7string \varnothing 57.6mm
- Chrome Cover 7string \varnothing 61.2mm
- P90 Sized Cover
- 12 Pole Screws
- Hairline Chrome Cover
- Hairline Gold Cover
- Gold Foil
- PVC Face Plate

SC Modern

This, SC Modern is the most representative single coil pickups of WSC. It has high output true single-coil for warm guitars with more sustain, fullness, and output - and less treble response.

The staggered Alnico 5 pole pieces are a stronger and deeper magnetic field. Extra coil windings provide extra power making this pickup great for heavier music styles.

They are wound with 42 AWG poly coated wire, resulting in tones that are brighter and more edgy. We recommend it for country, pop, blues, classic rock and heavy rock.

7S CV FL LF CP

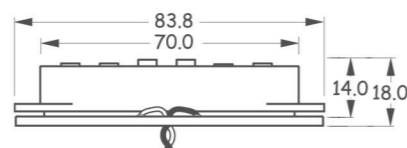
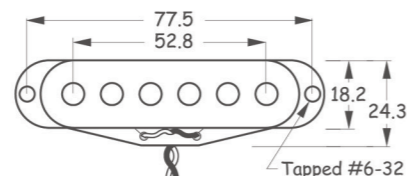

Model	TREBLE	MID	BASS	Out-Put
STA-N	4.0	8.0	7.0	95

Model	TREBLE	MID	BASS	Out-Put
STA-C	4.0	8.0	7.0	95

Model	TREBLE	MID	BASS	Out-Put
STA-B	3.5	8.0	7.5	120

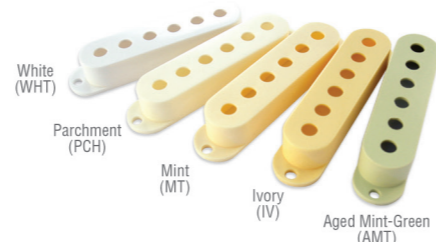

STA-N
#10001W

STA-C
#10002W

STA-B
#10003W

Neck
Alnico 5 ROD
Cloth Lead Wire
5.6K

Center
Alnico 5 ROD
Cloth Lead Wire
RWRP / 5.8K

Bridge
Alnico 5 ROD
Cloth Lead Wire
6.4K



Color / White



V2-N-WHT

V2-C-IV

V2-B-ADMT

Colors
White / Ivory / Aged Mint-Green

Vintage Strat®

This vintage model is extremely balanced true single-coil pickup. Pure, full-bodied early '50s single coil with natural sustain and low string pull from the Alnico # 2 magnets which provides punch and brightness on the low strings.

This is made to replicate similar Fender®1955 pickups, in look, tone, and feel. WSC vintage is based on the rounder, fatter tones of the original '54 to '57. Recommended for country, pop, rockabilly, blues, and classic rock.

RW

Model	TREBLE	MID	BASS	Out-Put
V2-N	4.5	7.5	6.5	95

Model	TREBLE	MID	BASS	Out-Put
V2-C	4.0	6.5	6.5	95

Model	TREBLE	MID	BASS	Out-Put
V2-B	5.0	8.5	8.0	95

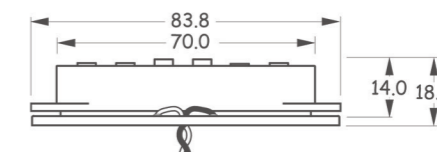
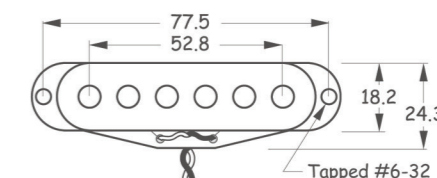

V2-N
#10201W

V2-C
#10202W

V2-B
#10203W

Neck
Alnico 2 ROD
Cloth Lead Wire
Plain Enamel
Grey Bottoms
5.6K

Center
Alnico 2 ROD
Cloth Lead Wire
Plain Enamel
Grey Bottoms
RWRP / 5.8K

Bridge
Alnico 2 ROD
Cloth Lead Wire
Plain Enamel
Grey Bottoms
6.4K



'61s Strat®

This modern vintage set is one of WSC vintage pickup lines and over wind it for more mid-range, punch, and output - the result is a pickup with well-dressed. Staggered Alnico 5 magnets, formvar magnet wire and cloth output wires make these pickups the choice of many players. Featuring pickups calibrated for each position and a reverse-coil, reverse-wound middle pickup for noise cancellation. If anybody wants plenty of mid-range and crisp high-end bite, this is just right one.

7S CV FL LF

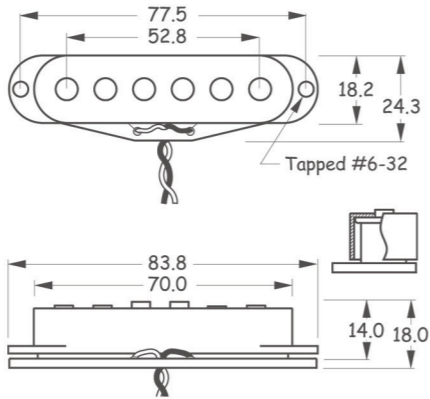

S61-N
#10301W

Neck
Alnico 5 ROD
Cloth Lead Wire
Formvar
5.6K

S61-C
#10302W

Center
Alnico 5 ROD
Cloth Lead Wire
Formvar
RWRP / 5.8K

S61-B
#10303W

Bridge
Alnico 5 ROD
Cloth Lead Wire
Formvar
6.4K

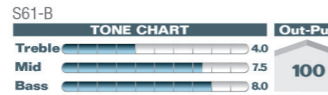
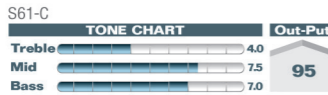
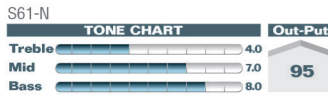

Memphis Blue

This Memphis Blues has the smooth creamy jazz tone but can take gain and rock hard when played it. Full rounded shoulders with a balanced tone. Nice clean, clear and bright tones delivered. It is great for blues, jazz, and rock as well.

7S CV FL LF

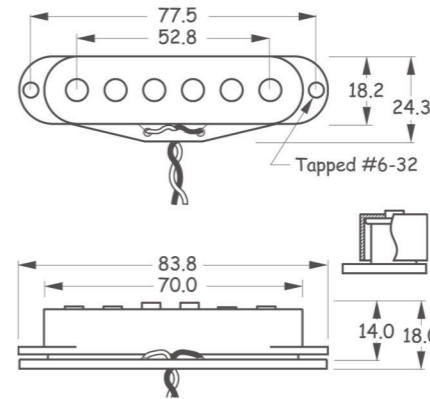

MB-N
#10501W

Neck
Alnico 2 ROD
Cloth Lead Wire
Grey Bottoms
6.5K

MB-C
#10502W

Center
Alnico 2 ROD
Cloth Lead Wire
Grey Bottoms
RWRP / 6.8K

MB-B
#10503W

Bridge
Alnico 2 ROD
Cloth Lead Wire
Grey Bottoms
7.6K

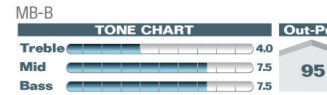
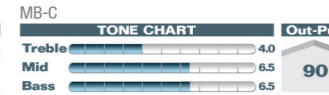
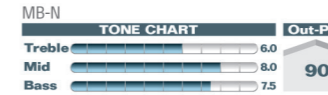

'74s Strat®

WSC '74 Strat® offers a bright and punchy mid '70s voiced Strat® coil pickups with solid bass response and a dynamic, woody character with fantastic snap in the high-end. It delivers a smooth, unadulterated tone with excellent pick attack from a combination of Alnico 5 magnets. Also the higher output with modern edge to the sound are for a more driven tone and increased midrange presence over vintage spec pickups. Rock, classic rock and country are highly recommended.

7S CV FL LF

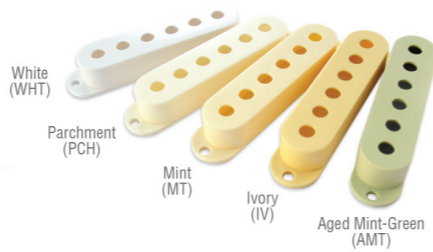

S74-N
#10401W

Neck
Alnico 5 ROD
Cloth Lead Wire
Plain Enamel
5.6K

S74-C
#10402W

Center
Alnico 5 ROD
Cloth Lead Wire
Plain Enamel
RWRP / 5.8K

S74-B
#10403W

Bridge
Alnico 5 ROD
Cloth Lead Wire
Plain Enamel
6.4K

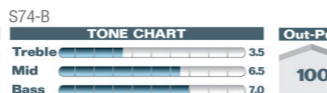
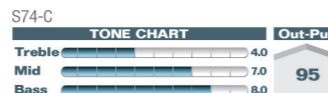
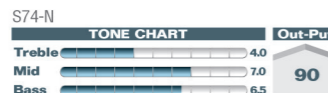

QSTA

7S CV

This pickup is built for those who want more powerful and punchy tone players. It's clean at lower volumes and screamin when cranked. The quarter-inch diameter magnets are matched with a powerful coil winding to deliver great sustain, making this one of our most popular single-coil pickups.

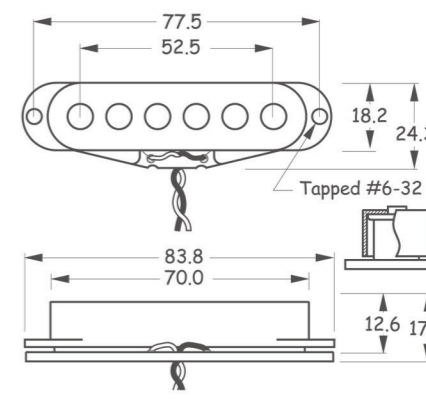
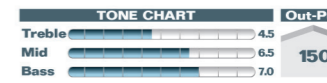

QSTA-N
#10601W

Neck
Alnico 5 ROD
Flex PVC
11.8K

QSTA-C
#10602W

Center
Alnico 5 ROD
Flex PVC
11.8K

QSTA-B
#10603W

Bridge
Alnico 5 ROD
Flex PVC
11.8K

SK52

This pickup set is designed for a truer vintage tone. Reverse engineered from '63 vintage Strat®, these pickups deliver almost same as the original vintage Strat® sound, and the toller bobbin delivers long sustain and rich mid-low range. The staggered, beveled edge Alnico 5 magnets with urethane magnet wire produce glistening highs and warm lows that are unmistakably vintage.

SK52-N		Out-Put
Treble	2.5	60
Mid	5.0	
Bass	4.5	
SK52-C		Out-Put
Treble	3.0	70
Mid	5.5	
Bass	5.0	
SK52-B		Out-Put
Treble	3.0	80
Mid	6.0	
Bass	6.0	

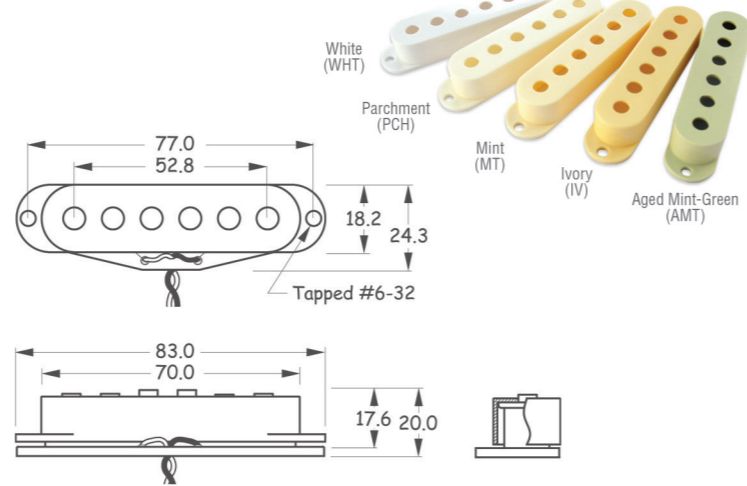

SK52-N
#11101W
Neck
Alnico 5 ROD
Cloth Lead Wire
4.9K

SK52-C
#11102W
Center
Alnico 5 ROD
Cloth Lead Wire
RWRP / 5.3K

SK52-B
#11103W
Bridge
Alnico 5 ROD
Cloth Lead Wire
5.7K



FSA

CV

FSA single coil set is designed for the players who want anything but a vintage tone. Specially, a piece of pure still under high string magnets provides balance of tone. All the character and extended frequency response of a true single coil partnered with a hot wind of modern plain enamel wire and Alnico 5 flat rods produce a high output with real contemporary character.

FSA-N		Out-Put
Treble	4.0	100
Mid	7.0	
Bass	7.0	
FSA-B		Out-Put
Treble	4.5	150
Mid	7.5	
Bass	8.0	

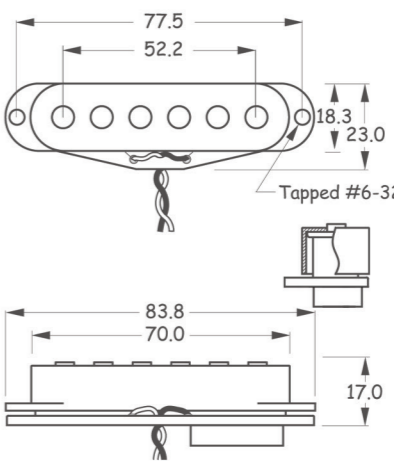

FSA-N-BLK
#11201B
Neck
Alnico 5 ROD
Cloth Lead Wire
Plain Enamel
5.6K

FSA-B-WH
#11203W
Neck
Alnico 5 ROD
Cloth Lead Wire
Plain Enamel
7.3K

SV5

CV

This SV5 single coil features the flat Alnico 5 rod magnets. It retains string volume balance and gives the entire sound a much deeper presence.

SV5-N		Out-Put
Treble	4.0	250
Mid	7.5	
Bass	5.5	
SV5-C		Out-Put
Treble	4.0	250
Mid	7.5	
Bass	5.5	
SV5-B		Out-Put
Treble	4.0	250
Mid	7.5	
Bass	5.5	

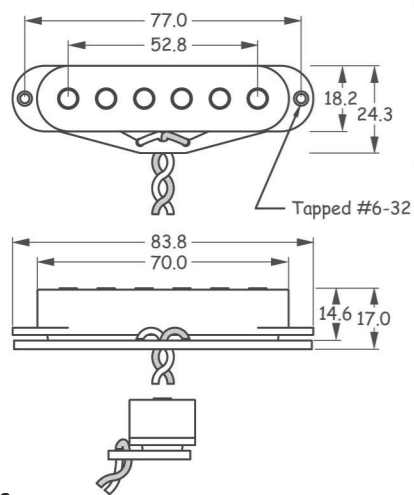

SV5-N
#10101W
Neck
Alnico 5 ROD
Cloth Lead Wire
11.4K

SV5-C
#10102W
Center
Alnico 5 ROD
Cloth Lead Wire
RWRP / 11.4K

SV5-B
#10103W
Bridge
Alnico 5 ROD
Cloth Lead Wire
11.4K



Custom Strat

7S CV FL

This set is same as FSA's figurations, but has flat bobbin for various purposes. The coil is wrapped with cooper tape for less noise.

CST-N		Out-Put
Treble	4.0	80
Mid	6.5	
Bass	7.0	
CST-C		Out-Put
Treble	4.0	120
Mid	6.5	
Bass	7.5	
CST-B		Out-Put
Treble	4.0	120
Mid	6.5	
Bass	7.5	

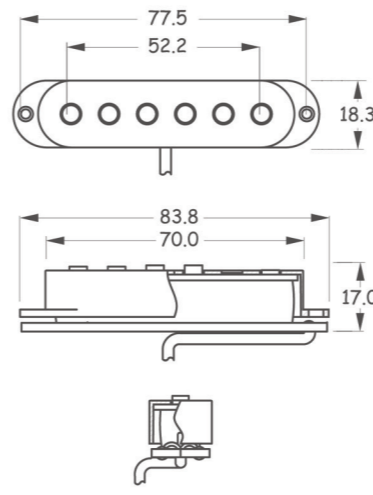

CST-N
#11301W
Neck
Alnico 5 ROD
2P Shield
5.6K

CST-C
#11302W
Center
Alnico 5 ROD
2P Shield
RWRP / 5.8K

CST-B
#11303W
Bridge
Alnico 5 ROD
2P Shield
6.4K





SF Ceramic

Same figuration as ST Ceramic model with plat top poles, but the high sensitive bobbin could not be compared with any other regular ceramic pickups.

7S CV LF

SF30
#13101B

Neck
Ceramic Bar
Flex PVC
5.3K

SF33
#13201B

Neck
Ceramic Bar
Flex PVC
5.3K

Colors

SF30 TONE CHART		Out-Put
Treble	5.0	170
Mid	6.0	
Bass	8.0	
SF33 TONE CHART		Out-Put
Treble	4.0	130
Mid	7.5	
Bass	6.5	

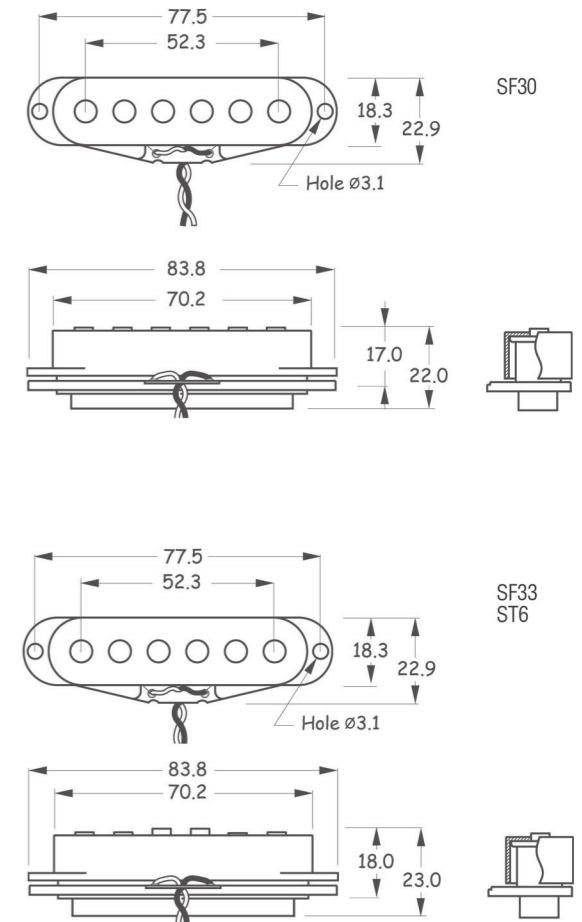

ST Ceramic

7S CV LF

This model is based on ceramic magnet single pickups lines of WSC. It is consisted of staggered top #1010 steel poles and #8 ceramic bar magnets with plastic bobbin. These will give a different flavor that might be suitable for certain styles or tastes, and they have a distinctive meatiness to them that sounds good for some nasty blues playing.

ST7-CD
#13601B

Neck
Ceramic Bar
Flex PVC
5.4K

ST5
#13301W

Neck
Ceramic Bar
Flex PVC
5.3K / 50m/m Pitch

ST6
#13401W

Neck
Ceramic Bar
Flex PVC
5.4K

ST7
#13501B

Neck
Ceramic Bar
Flex PVC
5.4K

ST7-CD TONE CHART		Out-Put
Treble	4.0	130
Mid	7.0	
Bass	7.0	
ST5 TONE CHART		Out-Put
Treble	3.0	150
Mid	6.0	
Bass	7.5	
ST6 TONE CHART		Out-Put
Treble	3.5	150
Mid	7.0	
Bass	8.0	
ST7 TONE CHART		Out-Put
Treble	5.0	150
Mid	6.0	
Bass	8.0	



Stacked Singles

This stacked single coil is that have 2 double bobbins. This feature was created primarily so that they could have pickups with the sound of single-coil, but with the noise cancellation of humbucker which usually has a closer to singles, without the noise of the same sound. It is even richer than real vintage coils with equal effervescence, highlighted by sweet, soft and

STK50-WH		Out-Put
Treble	6.0	205
Mid	6.5	
Bass	8.0	

STK62-WH		Out-Put
Treble	2.0	250
Mid	7.5	
Bass	5.0	

STK50-WH #25101
All Position
Alnico 5 Rods
4P Shield
10K

STK62-IV #25111V
All Position
Alnico 5 Rods
4P Shield
Plain Enamel
8.2K

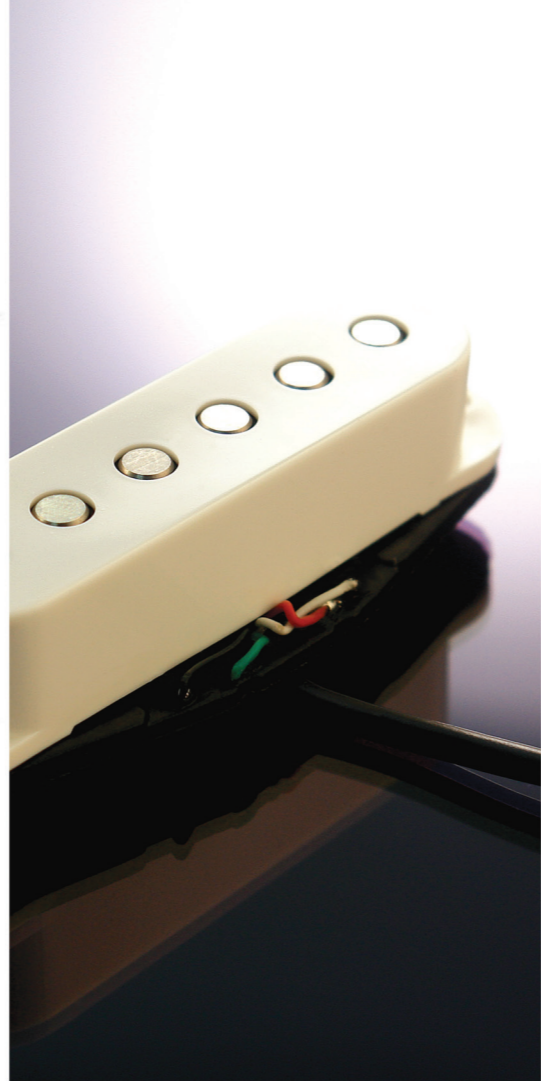
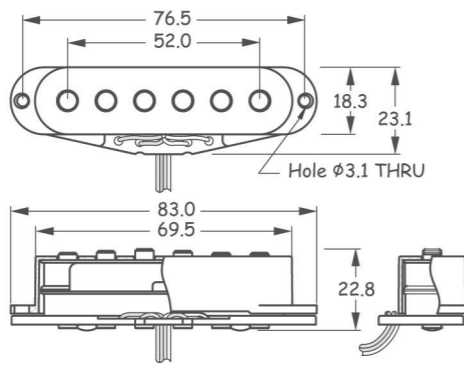
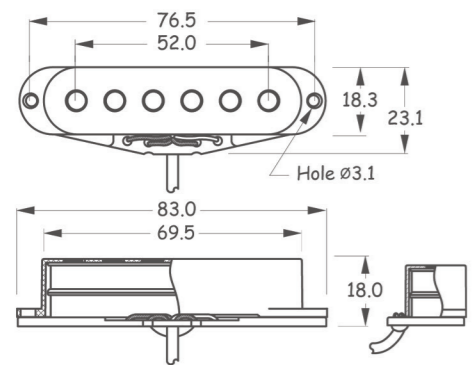

7STA SEVEN String Singles

This staggered 7-string pickup provides a distinct vintage tone with greater sustain and full sounding harmonics. A high-output, ture single-coil pickup for warm-toned, 7-string guitars that's ideal for playing Texas blues rock, classic rock.

RW CV SG CP

7STA		Out-Put
Treble	4.5	110
Mid	6.0	
Bass	8.0	

7STA-CD		Out-Put
Treble	5.0	100
Mid	7.5	
Bass	8.0	

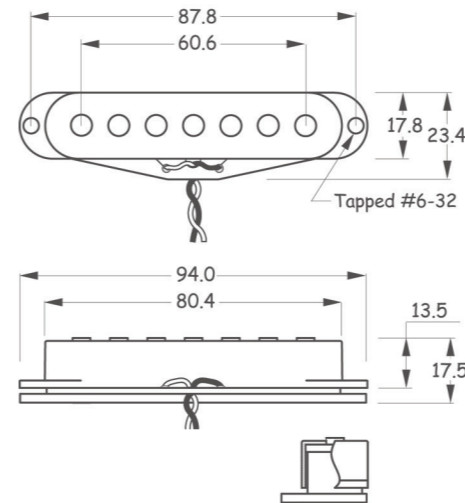

7STA #17101B
Alnico 5 Rods
Cloth Lead Wire
7.4K

7STA-CD #17201W
Alnico 5 Rods
Cloth Lead Wire
7.4K

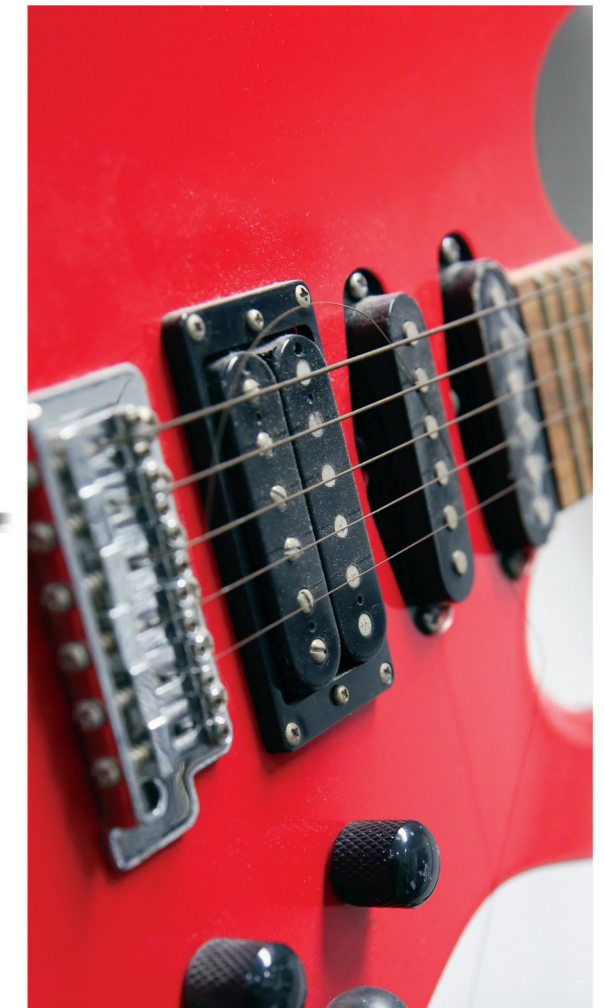

SM5S Passive

It is the same pickup as SM5G, but passive which is perfect to complement high output, dual-coil pickups in the same electric guitar. The SM5G features a prominent mid-range while the low frequency response is clear, but very full and powerful.

SM5S		Out-Put
Treble	4.5	135
Mid	6.5	
Bass	8.0	

SM5S-WH #24201W
All Positon
Ceramic Bar
2P Shield
5.6K

SM5S #24201
All Positon
Ceramic Bar
2P Shield
5.6K

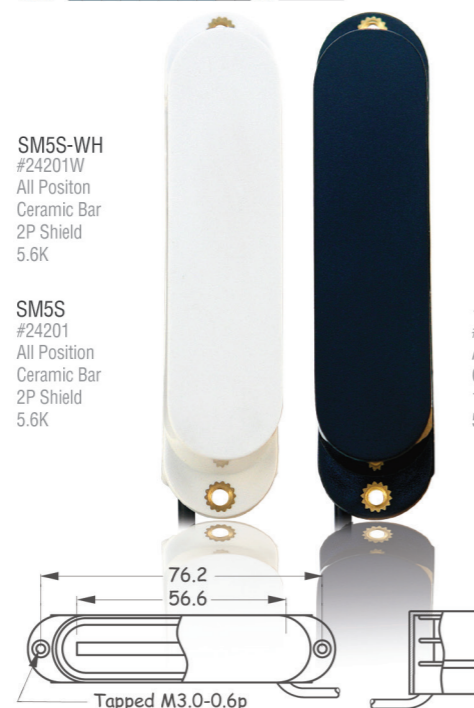

SM5G Active

This active single pickup has 'plucky' percussive attack, but much smoother, less scratchy distortion sound and more output. It's so quiet that it's impossible to tell the guitar is even plugged in at high gain levels.

SM5G		Out-Put
Treble	4.5	250
Mid	6.5	
Bass	8.0	

SM5G-WH #24101W
All Positon
Ceramic Bar
1P Braided Shield
5.6K

SM5G #24101
All Positon
Ceramic Bar
1P Braided Shield
5.6K



VOX® Ceramic

This is kind of vintage VOX® Phantom style with open and chrome plated cover. This model is also based on ceramic magnets single pickup lines of WSC. It is consisted of staggered top #1010 steel poles and #8 ceramic bar magnets with plastic bobbin. These will give a different flavor that might be suitable for certain styles or tastes, and they have a distinctive meatiness to them that sounds good for some nasty blues playing.

RW CV SG CP

SR4		Out-Put
Treble	4.5	160
Mid	7.0	
Bass	7.5	



SR4 #14401CV
Neck
Ceramic Bar
2p Shield
5.4K

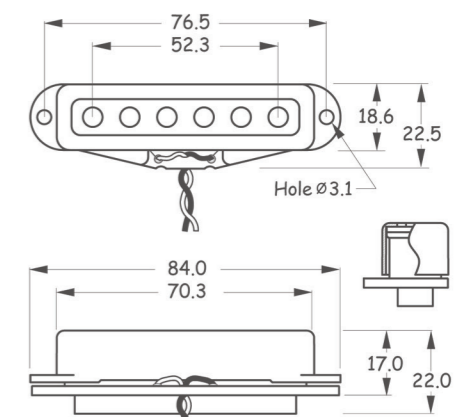

QS6 Ceramic

This Queen of single pickups has high output and more powerful tone by ceramic magnet. The extra big diameter pole pieces which is pure 1010 and over wound coils give you maximum output and a full frequency response. Recommended for heavy metal and rock, classic metal

QS6-N
#15101

Neck
Ceramic Bar
Flex PVC
8.26K

QS6-C(Center)
#15102

QS6-B(Bridge)
#15103

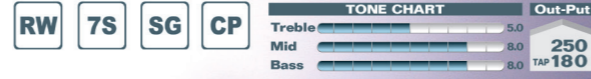
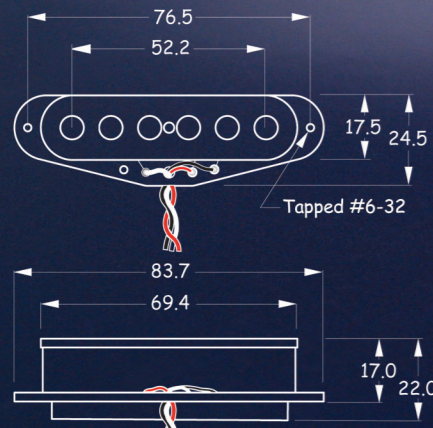

KS6 Alnico

This King of single pickups also has high output and more powerful tone, and more clean and smoother tone by Alnico 5 magnets. The extra big diameter pole pieces and over wound coils give you maximum output and a full frequency response. Recommended for heavy metal and rock, classic metal.



KS6-N
#15201

Neck
Alnico 5 Rods
Flex PVC
8.26K

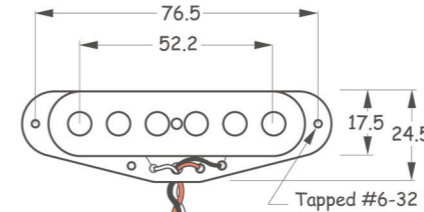

KS6-C(Center)
#15202

KS6-B(Bridge)
#15203

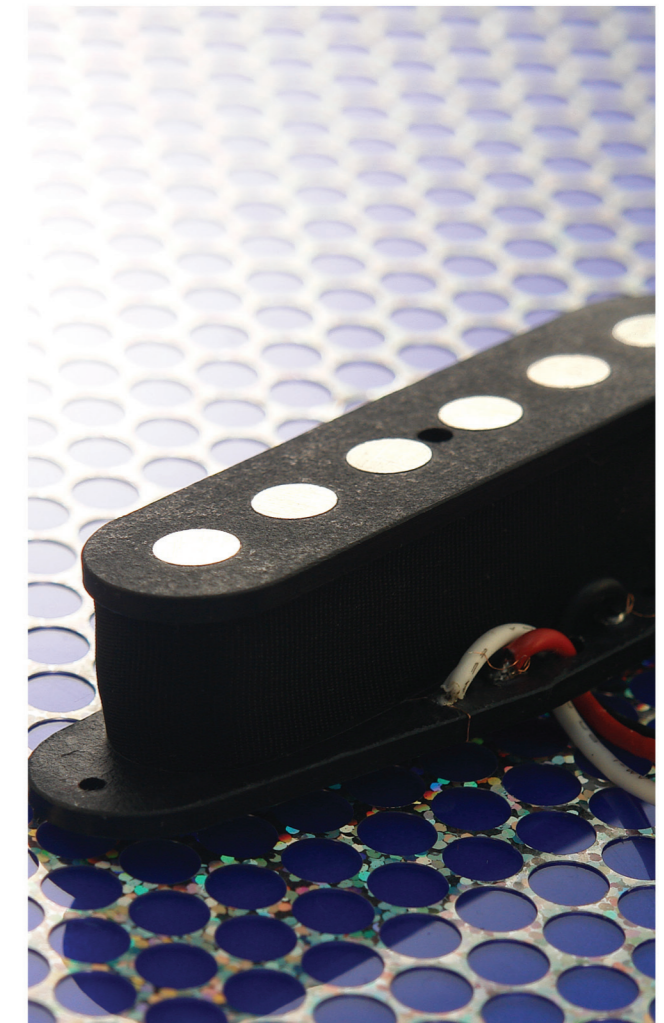

Quarter Pound Slim

This set of the King is for the pickguard load or other purposes like regular single pickups.

This King of single pickup also has high output and more powerful tone, and more clean and smoother tone by Alnico 5 magnets. The extra big diameter pole pieces and over wound coils give you maximum output and a full frequency response. Recommended for heavy metal and rock, classic metal.

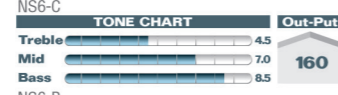
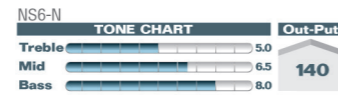

NS6-N
#15301

Neck
Alnico 5 Rods
Flex PVC
6.4K

NS6-C
#15302

Center
Alnico 5 Rods
Flex PVC
RWRP/6.4K

NS6-B
#15303

Bridge
Alnico 5 Rods
Flex PVC
6.6K

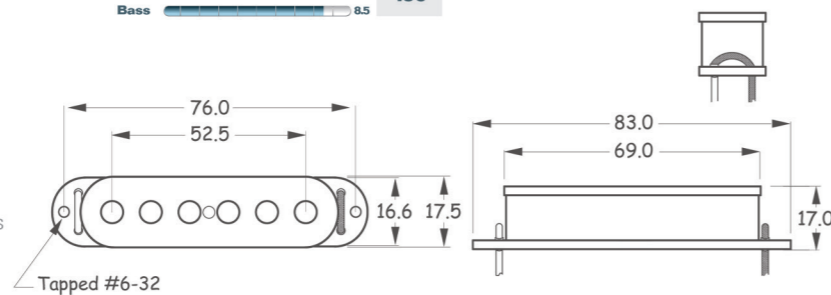

Disclaimers: Fender®-Strat®, Stratocaster®, Tele®, Jazzmaster®, Jaguar®, and Mustang® are registered trademarks of Fender® Musical Instruments. Gibson®-Les Paul®, P-90®, Flying V® are registered trademarks of Gibson Guitar Corp. Music Man® is a registered trademark of Ernie Ball Corp. Rickenbacker® is a registered trademark of Rickenbacker International Corp. Woo Sung Chorus Industries is not affiliated with these companies.



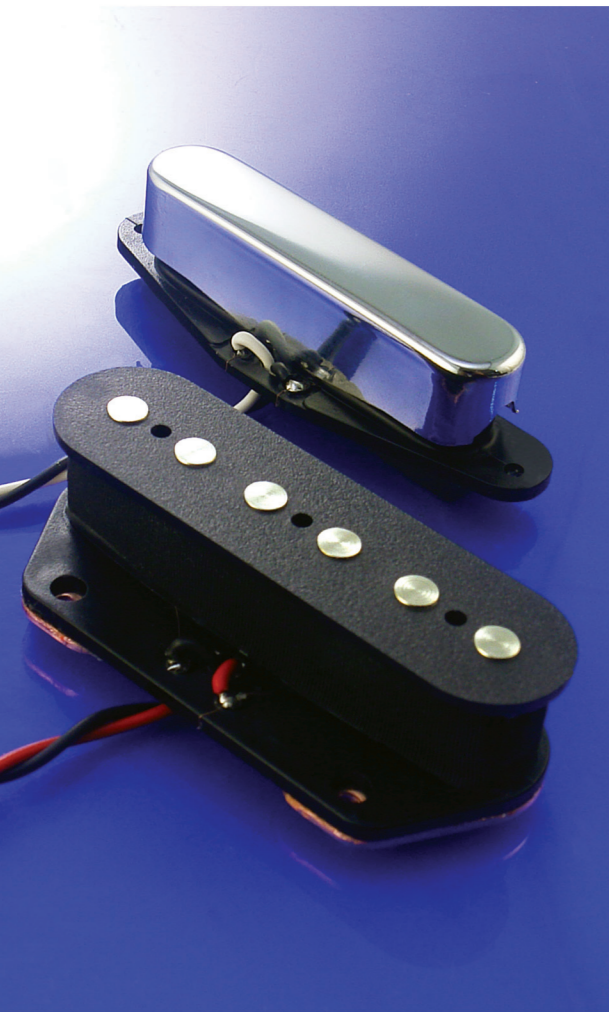

TE Ceramic

This set of pickups give you the classic Tele® that of the yester-years. These pickups have a modest output and a soft, round attack. Perfect for warmth and fatness without over doing it. These pickups are wound, by machine, and use ceramic 8 bar magnet and pure 1010 steel poles to produce a crunchy and higher tone.



TE-N
#16101

Neck
Ceramic Bar
Flex PVC
4.2K

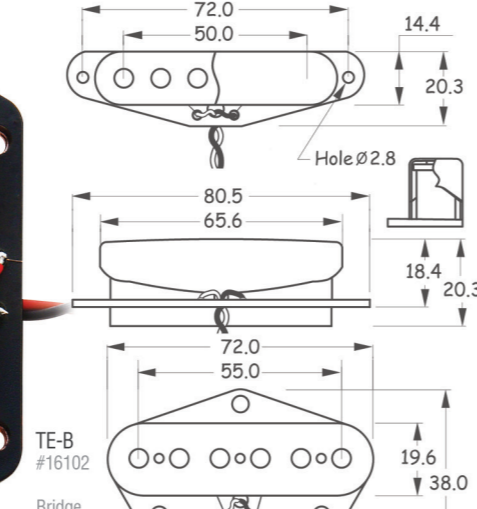

TE-B
#16102

Bridge
Ceramic Bar
Flex PVC
5.9K



Model	Treble	Mid	Bass	Out-Put
TE-N	4.0	6.5	7.0	120
TE-B	4.5	7.0	6.5	140

TE6-N

Treble	Mid	Bass	Out-Put
4.5	6.0	8.0	180

TE6-B

Treble	Mid	Bass	Out-Put
3.5	6.5	7.5	330

TE6

These have the bigger 6.5mm (1/4) alnico pole pieces. These fat magnets create a unique sound with more bass and more mellow and sweet, less harsh tone than the smaller standard pole pieces. And they have the same copper-shielding foil around the coil that is a big part of that magic look





TE6-N
#16501

Neck
Alnico 5 Rod
Cloth Lead Wire
9.7K

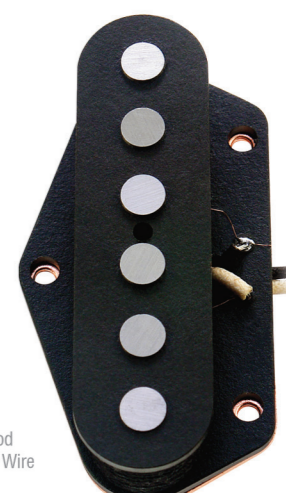

TE6-B
#16502

Bridge
Alnico 5 Rod
Cloth Lead Wire
15K

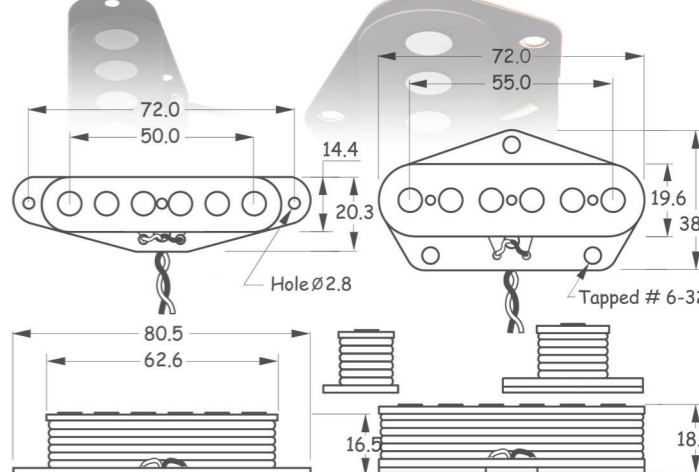

Model	Treble	Mid	Bass	Out-Put
TE6-N	4.5	6.0	8.0	180
TE6-B	3.5	6.5	7.5	330

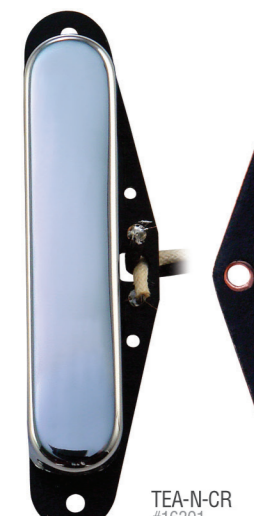

TEA-N-CR
#16301

Neck
Alnico 5 Rod
Cloth Lead Wire
5.73K

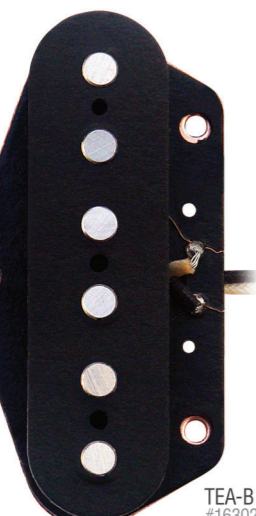

TEA-B
#16302

Bridge
Alnico 5 Rod
Cloth Lead Wire
6.62K



Model	Treble	Mid	Bass	Out-Put
TEA-N	4.5	7.5	8.0	110
TEA-B	4.5	7.0	6.5	180

TEK

This set of pickups imparts all of the classic twang of a vintage Tele® with one very important distinction: no 60 cycle hum and virtually no noise. The pickup utilizes, hum canceling, stack technology for unsurpassed quietness. The 6 pole piece construction gives the pickup a bright, punchy sound, while retaining a vintage look.

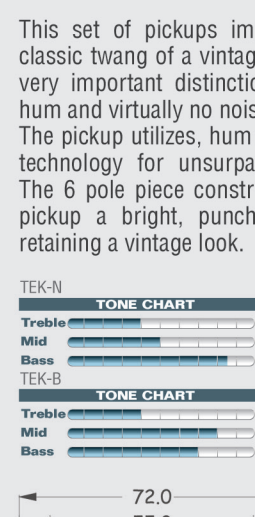

TEK-N
#16401

Neck
Alnico 5 Rod
4P Shield
4.4K

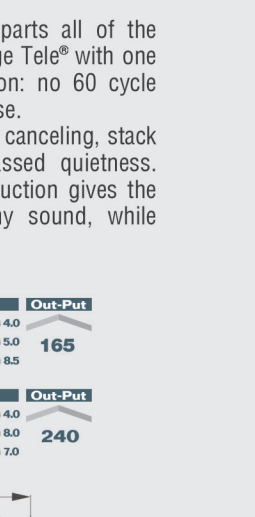

TEK-B
#16402

Bridge
Alnico 5 Rod
4P Shield
10.9K

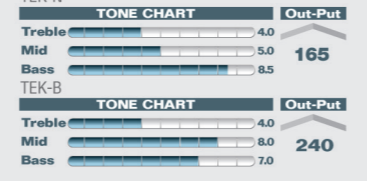

Model	Treble	Mid	Bass	Out-Put
TEK-N	4.0	5.0	8.5	165
TEK-B	4.0	8.0	7.0	240

TEL

This TEL tele pickup has the long and flat cover for the neck position. The neck pickup's taller bobbin is designed to accommodate more windings, combined with a slightly shorter bridge pickup bobbin for dark full-bodied midrange.



TEL-N

Treble	Mid	Bass	Out-Put
2.5	6.5	4.5	240



TEL-N-CR
#16312

Neck
Alnico 5 Rod
Cloth Lead Wire
Plain Enamel
6.0K

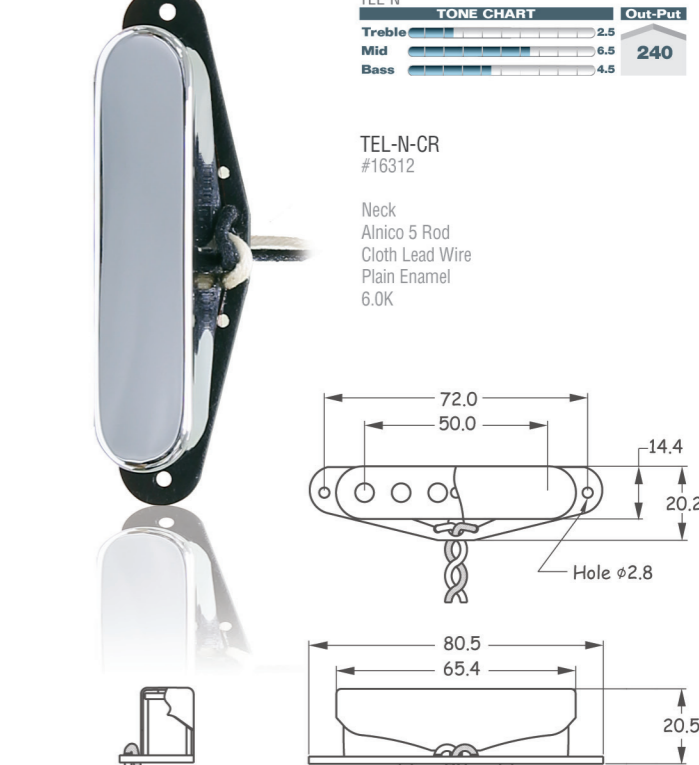

Model	Treble	Mid	Bass	Out-Put
TEL-N	2.5	6.5	4.5	240

SHR

Hot blade humbucker, or pickups in blade format. Can exist in any other ones, just do not have poles (screws) visible at the top. These have a bar-shaped magnet and a single blade as a pole. Also these have the advantage of capturing the sound evenly throughout its length, even when the guitarist applies techniques such as 'the bends' or 'vibrato'. Blues guitarists usually do not like this type of construction because they think we take the dynamics of the performer, which is extremely important in this style. Normally used in very high gain pickups, this model is preferred by heavy metal guitarists.



SHR		Out-Put
TONE CHART		
Treble	5.0	220
Mid	6.0	
Bass	6.5	
SHR-HALF		Out-Put
TONE CHART		
Treble	6.0	140
Mid	7.0	
Bass	9.0	

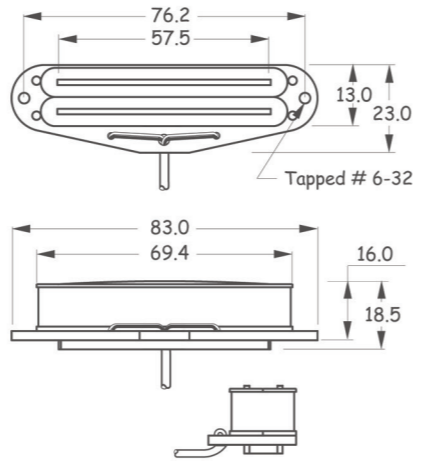

SHR #21101 Neck & Center Ceramic Bar 4P Shield 12.2K #21103 Bridge

SHR-WH #21101W Neck & Center Ceramic Bar 4P Shield 12.2K #21103W Bridge

SHR-ZB #21201 Neck & Center Ceramic Bar 4P Shield 12.2K #21203 Bridge

SHR-HALF #21301 Neck & Center Ceramic Bar 4P Shield 12.2K #21303 Bridge



SHS

Hot blade humbucker for pickguard mount or for others version. Can exist in any other ones, just do not have poles(screws) visible at the top. These have a bar-shaped magnet and a single blade as a pole. Also these have the advantage of capturing the sound evenly throughout its length, even when the guitarist applies techniques such as 'the bends' or 'vibrato'. Blues guitarists usually do not like this type of construction because they think we take the dynamics of the performer, which is extremely important in this style. Normally used in very high gain pickups, this model is preferred by heavy metal guitarists.

SHS		Out-Put
TONE CHART		
Treble	3.5	250
Mid	6.5	
Bass	8.0	

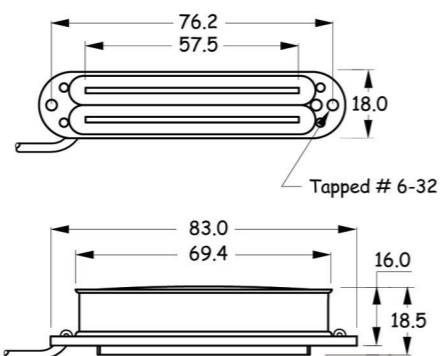

SHS #21401 Neck & Center Ceramic Bar 4P Shield 12.2K #21403 Bridge



TEH

Hot blade humbucker for Tele® bridge version. Can exist in any other ones, just do not have poles(screws) visible at the top. These have a bar-shaped magnet and a single blade as a pole. Also these have the advantage of capturing the sound evenly throughout its length, even when the guitarist applies techniques such as 'the bends' or 'vibrato'. Blues guitarists usually do not like this type of construction because they think we take the dynamics of the performer, which is extremely important in this style. Normally used in very high gain pickups, this model is preferred by heavy metal guitarists.

TEH		Out-Put
TONE CHART		
Treble	4.5	250
Mid	6.5	
Bass	8.0	

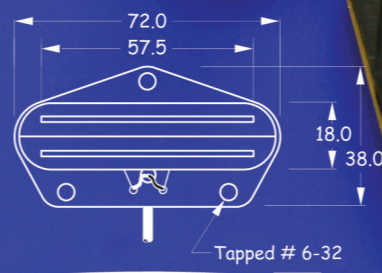

TEH-WH #16602W Bridge Ceramic Bar 2P Shield 12.2K

TEH-BLK #16602 Bridge Ceramic Bar 2P Shield 12.2K

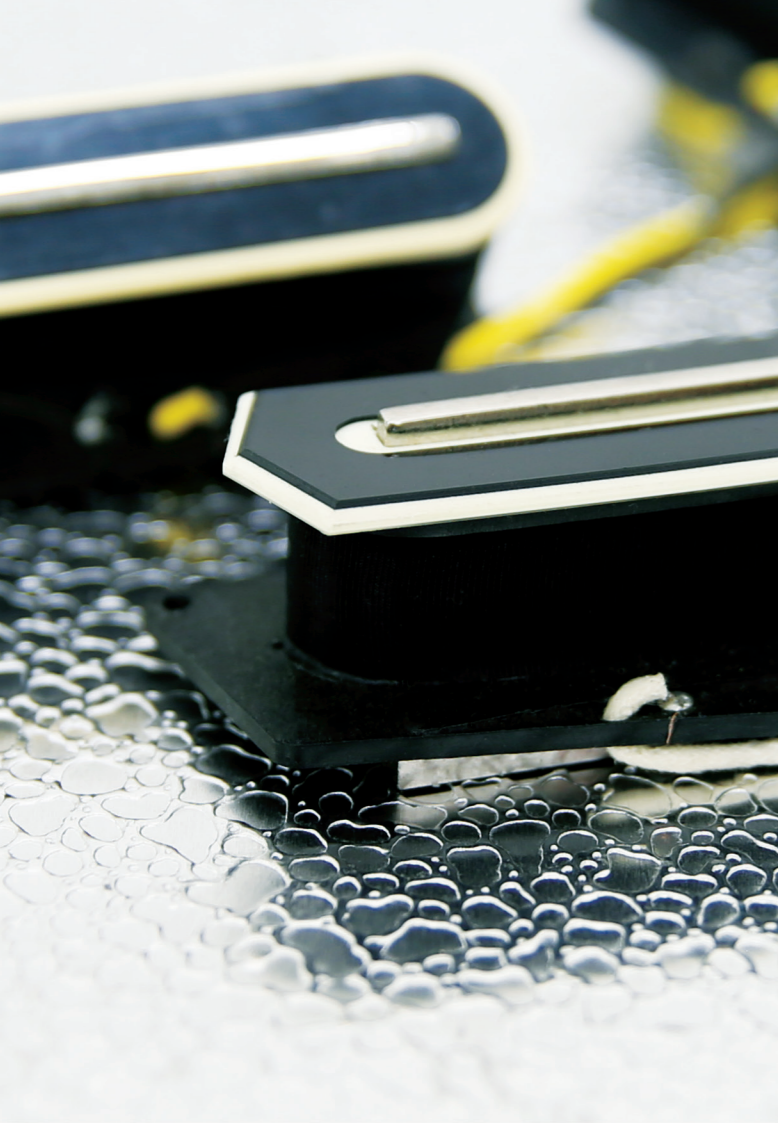

CHL-TF

Charlie Christian style pickup has a great sound with a palate of rich and deep tone. It is made with low resistance coil wound, a nickel plated blade and Alnico 3 bar magnets.

CHL-TF-BLK
#26731

Neck
Alnico 3 Bar
Cloth Lead Wire
3.2K

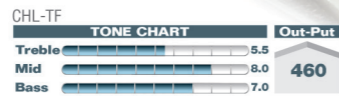
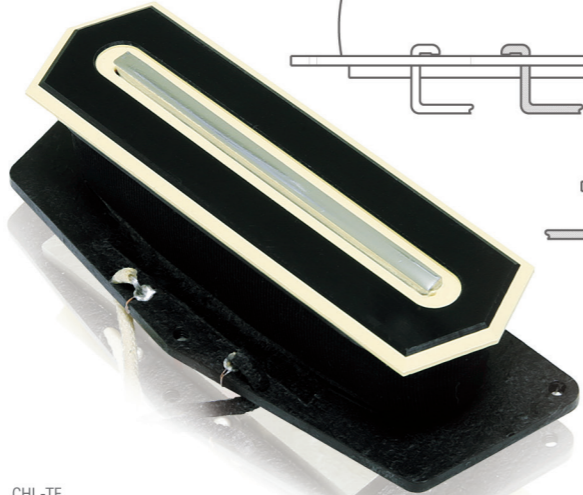
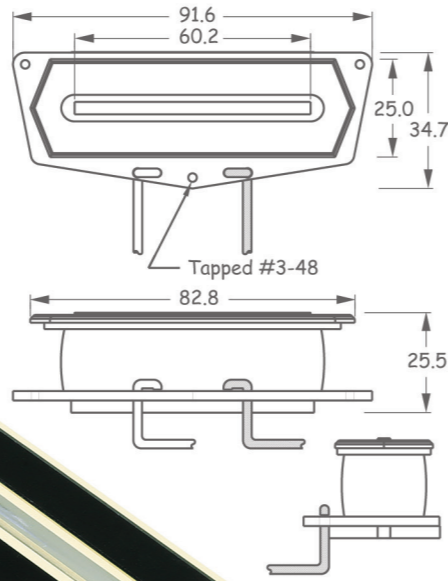

Custom Singles

Hex pole Screws

Nickel Invader

Black Invader

7 string Bobbin

8 string Bobbin



CHCB

Charlie Christian style Tele bridge pickup has a fat and clear tone with loads of sustain. It is made with a nickel plated blade and ceramic bar magnets.

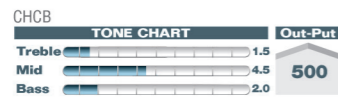

CHCB-BLK
#26753

Bridge
Ceramic Bar
Cloth Lead Wire
4.6K

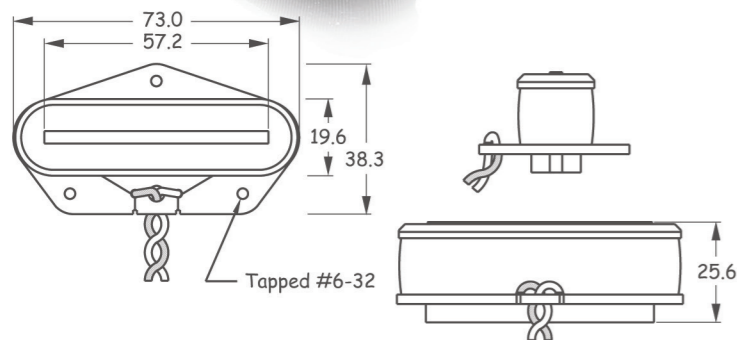

TEA-B STP

Tele Staple bridge pickup features beveled rectangular Alnico bar magnets as non-adjustable pole pieces. It has a definite P90 vibe, but with some added clarity and tightness, and a little bit of twang.

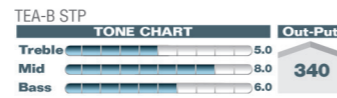

TEA-B STP
#16702

Bridge
Alnico 5 Bar
Cloth Lead Wire
6.6K

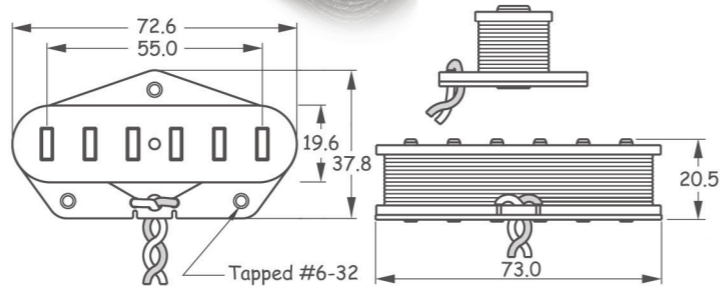



Solid Tube

This model is full size of lipstick pickup like Dano® pickups. This have also Alnico 5 bar magnet and wound directly on a large vintage correct bar magnet for giving the great tone.

TONE CHART		Out-Put
Treble	3.0	125
Mid	6.0	
Bass	9.0	



LS1
#22101

Neck & Bridge
Alnico 5 Bar
2P Shield
4.8K

#22102
Center

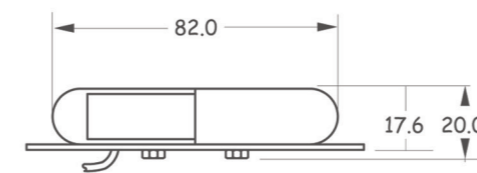
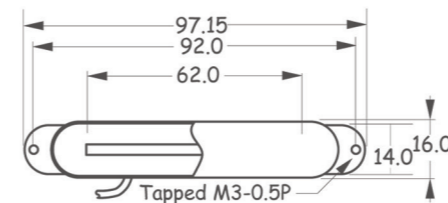

Mini Tube

This is a mini size of lipstick pickups, but it have ceramic 8 bar magnet and wound directly on a large vintage correct bar magnet for giving the great tone.

TONE CHART		Out-Put
Treble	3.0	110
Mid	6.5	
Bass	8.0	

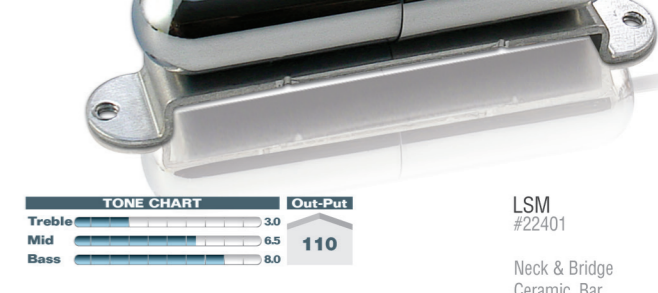

LSM
#22401

Neck & Bridge
Ceramic Bar
2P Shield
4.15K

#22402
Center

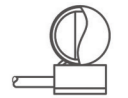
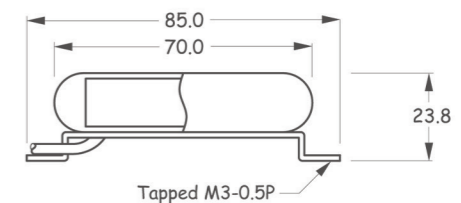
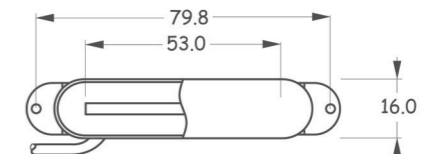

Hollow Tube

These pickups are just replica of Strat® single pickups with/without the folds and Alnico 5 bar magnet. These unlike most other lipstick pickups are wound directly on a large vintage correct bar magnet to bring out its own jangle tone.



LS2
#22301

Neck & Bridge
Alnico 5 Bar
2P Shield
4.8K

#22301
Center

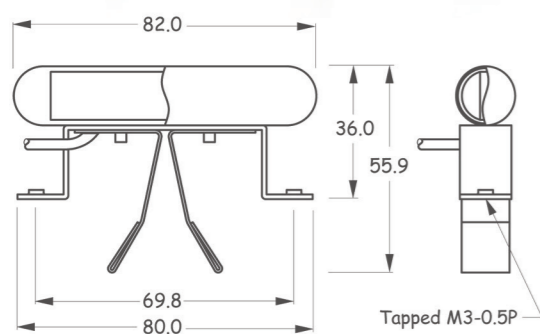

Tapped M3-0.5P



LS6
#22201

Neck & Bridge
Alnico 6 Bar
2P Shield
3.8K

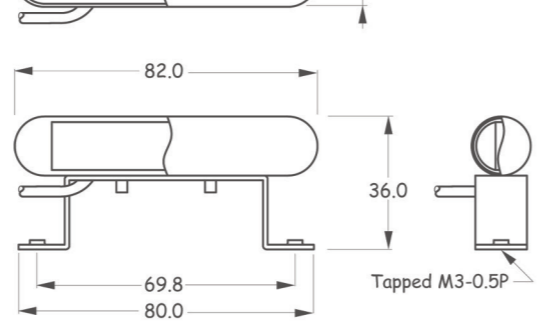

Tapped M3-0.5P



Twin Tube

Humbucker figuration with mini size of lipstick pickups, have ceramic 8 bar magnet with a special winding spec.

TONE CHART		Out-Put
Treble	4.5	250
Mid	6.5	
Bass	8.0	

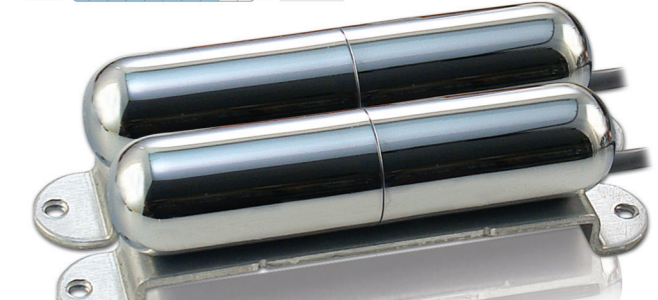

LTT
#22501

Neck & Bridge
Ceramic Bar
2P Shield
4.15K

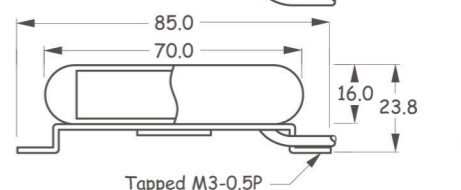
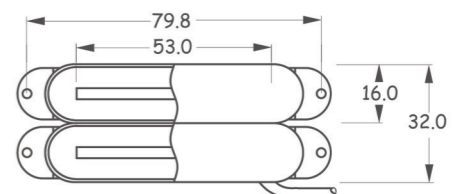

Tapped M3-0.5P

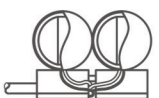

PBA

PBA pickup uses Alnico 5 rod magnets and a knifeedge gloss-cover hot coil wind that delivers a forceful sound with pushed midrange but tight bass and treble response. This pickup provides the humbucking punch and boom associated with the electric bass.

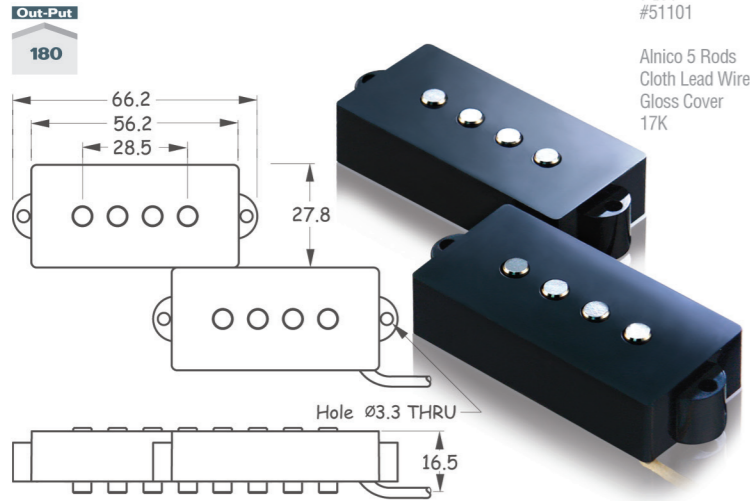

PBA20

Same as PBA, but mat cover smooth edge.

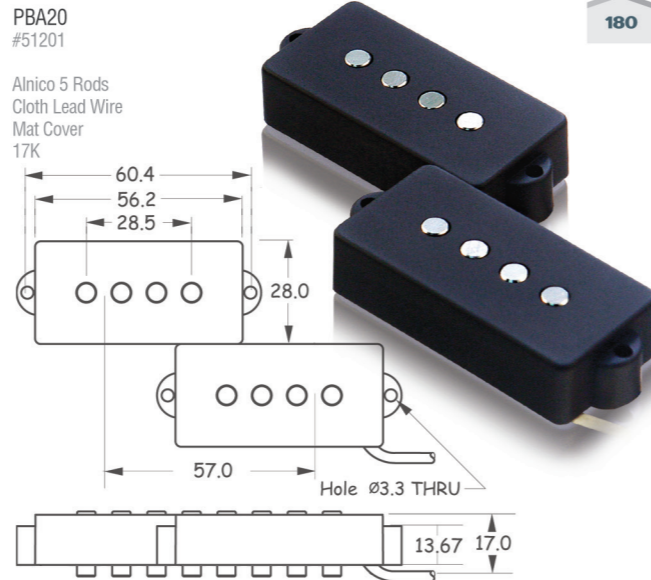

PBA5

PBA5 is the standard sized 5-string P-Bass style pickup with Alnico 5 rods magnets, mat and smooth edged cover. It has a warm, bright, and fat character.

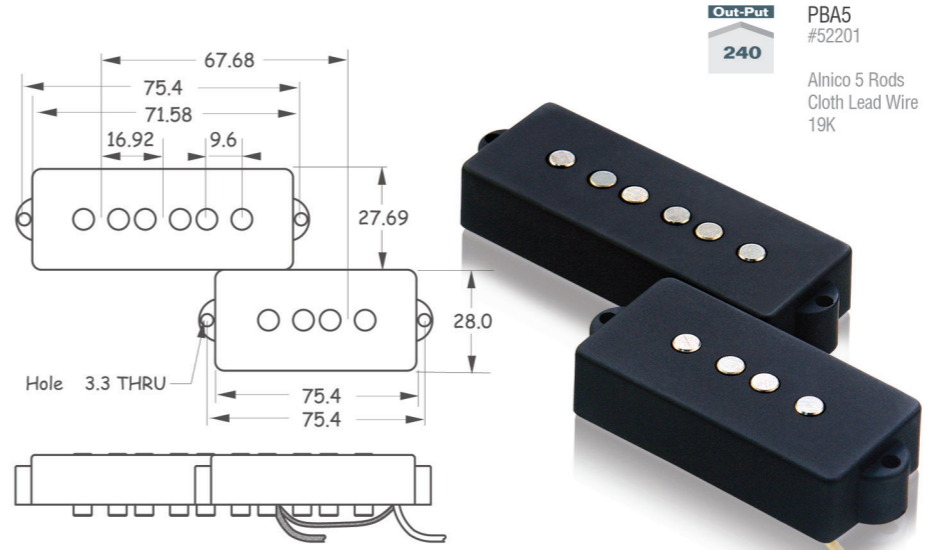

DPM5

DPM5 is 5 string unexposed P-bass pickup with Ceramic bar magnet and sealed by epoxy. While retaining the warm and rich low-end vintage, it expands the tonal range with an enhanced treble response perfect for players working in technical genres



PBZ

PBZ is a standard active replacement pickup for P-Bass® style, with sharper attack and more punch in the bass response. Battery life is approximately 2,000 continuous hours.

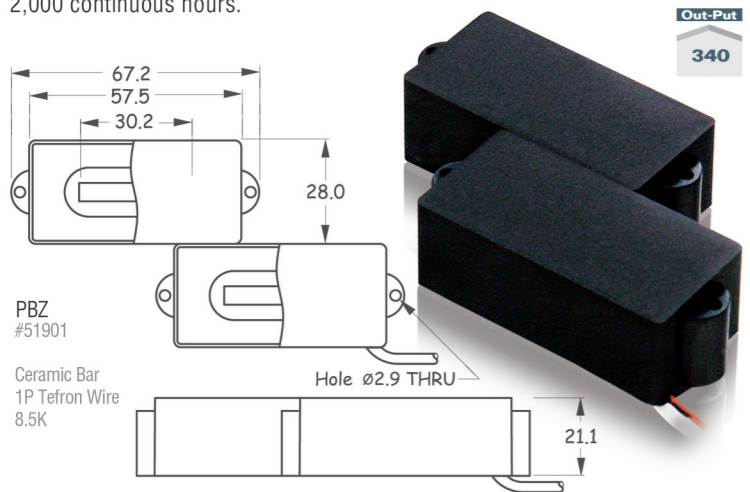

DPM4

DPM4 unexposed P-bass pickup with Ceramic bar magnet is even brighter than Alnico 5. And this epoxy sealed pickup makes the voice softer.

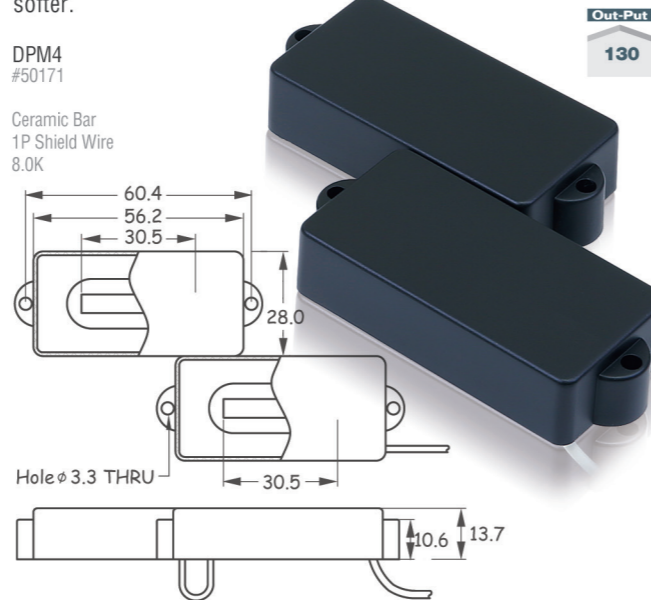

PBA6

PBA6 is contemporary designed 6-string P-Bass® style pickups with Alnico 5 rods magnets. Also it has well-balances set of pickups that provides a flexible array of tones.

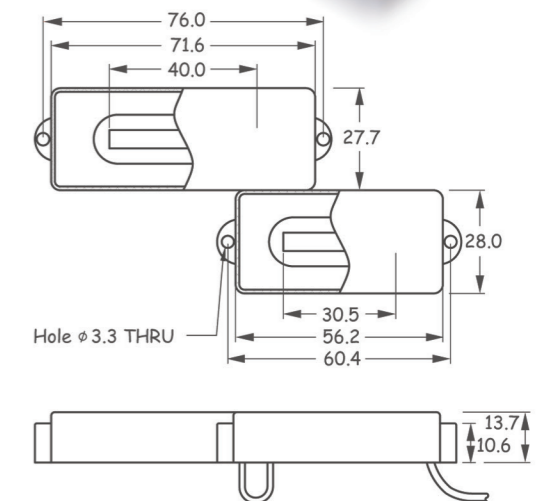
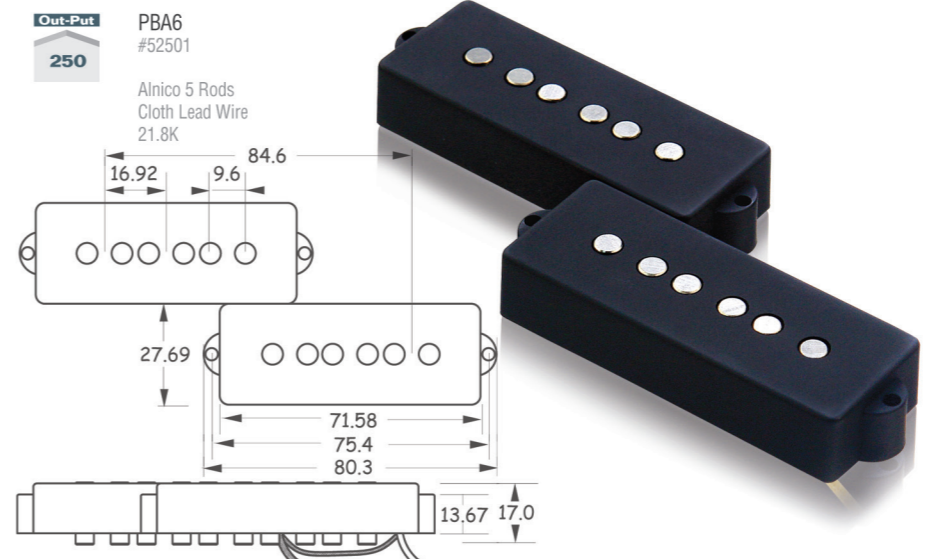

QPA

QPA has high output, versatile tone provides. The extra diameter pole pieces expand the magnetic field and extend the frequency ranges for fat, full, punchy sound with tremendous mid-range presence and maximum output.

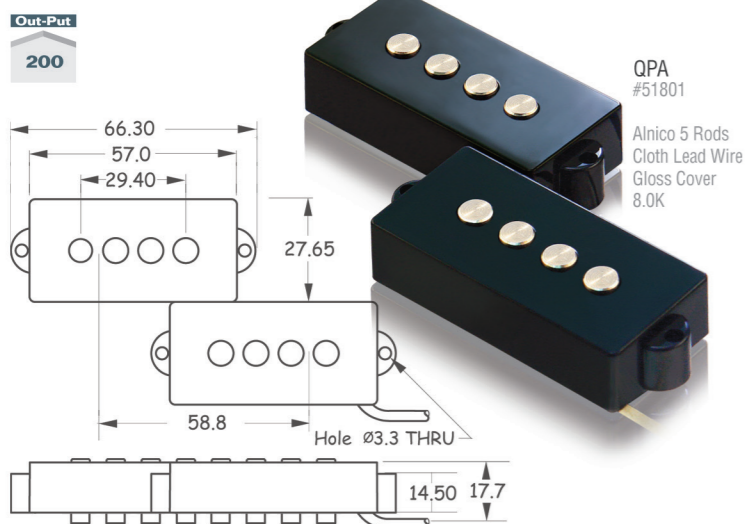

PM4

This Big-Poles grab all the strings movements with zero loss. Spe wound coils make up for a bass transducer ready to redefine the rock players, it loves droptuned basses and massive tone tweaking.



cially engineered ferrite magnets and custom word PRECISION. It is for nu-school funk and

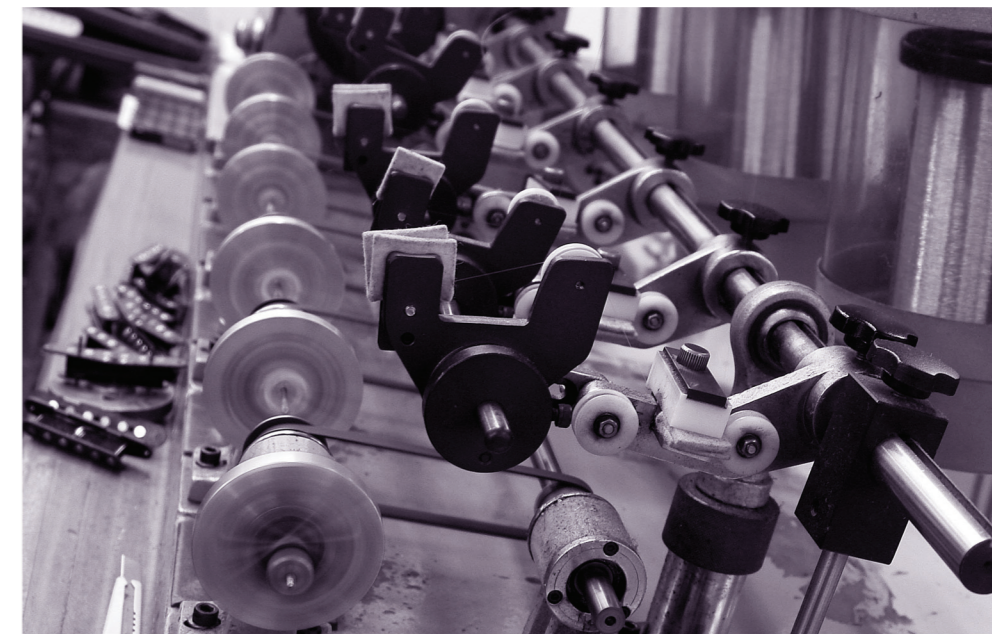
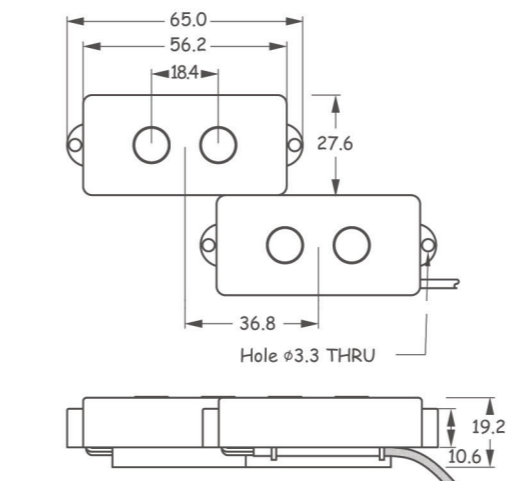

JBA

JBA is the most represented in J-Bass® style pickup line of WSC. Overwound for more punch, midrange, bass, and output, and delivers '60s Jazz Bass® tone. It is constructed with Alnico 5 magnets.

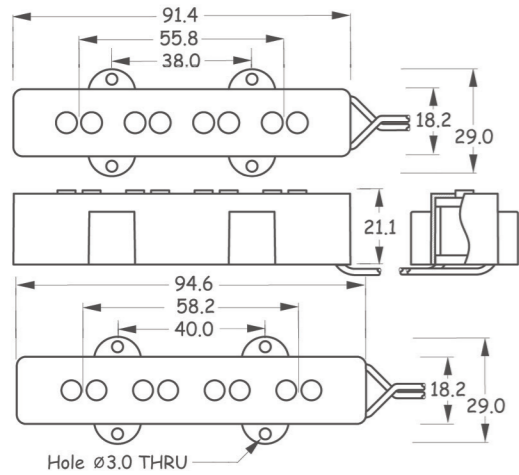

JBA-B
#53103
Bridge
Alnico 5 Rods
Cloth Lead Wire
Gloss Cover
7.82K

JBA-B
Out-Put
150

JBA-N
#53101
Neck
Alnico 5 Rods
Cloth Lead Wire
Gloss Cover
7.55K

JBA-N
Out-Put
140

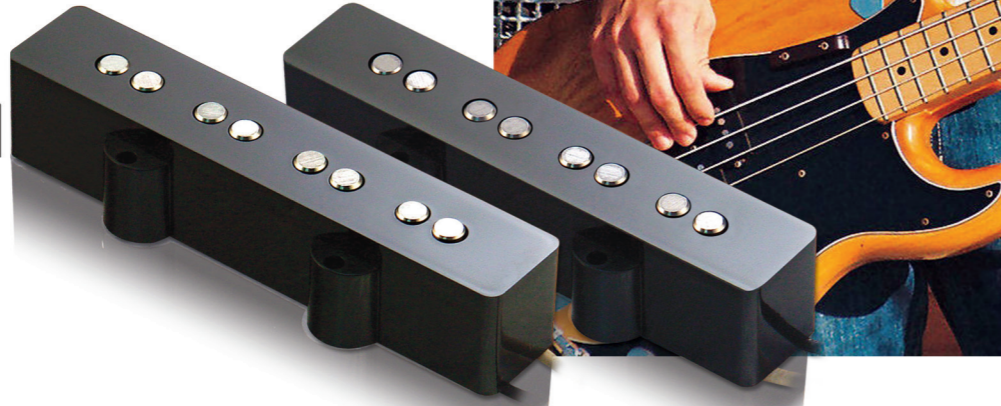

JBA-CD

JBA-CD is same as JBA model with closed top cover. Overwound for more punch, midrange, bass, and output, and delivers '60s Jazz Bass® tone. It is constructed with Alnico 5 magnets.

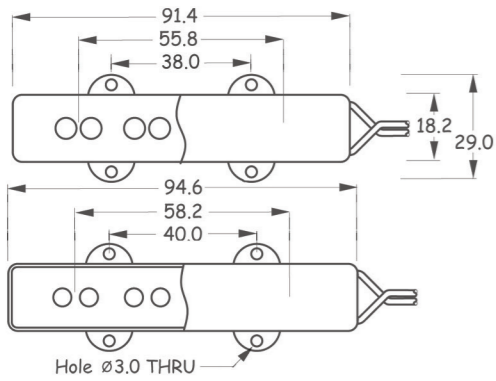

JBA-CD-B
#53113

Bridge
Alnico 5 Rods
Cloth Lead Wire
7.82K

JBA-CD-B
Out-Put
150

JBA-CD-N
Out-Put
140

JBA-CD-N
#53111
Neck
Alnico 5 Rods
Cloth Lead Wire
7.55K

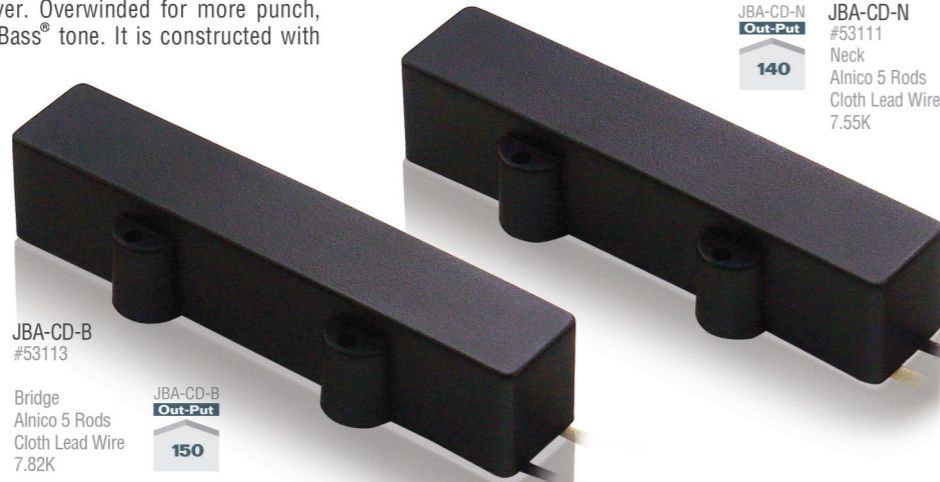

JM4

JM4 has high output and more powerful tone by ceramic magnet. The extra big diameter pole pieces which is pure 1010 and over wound coils give you maximum output and a full frequency response. Recommended for heavy metal and rock, classic metal.

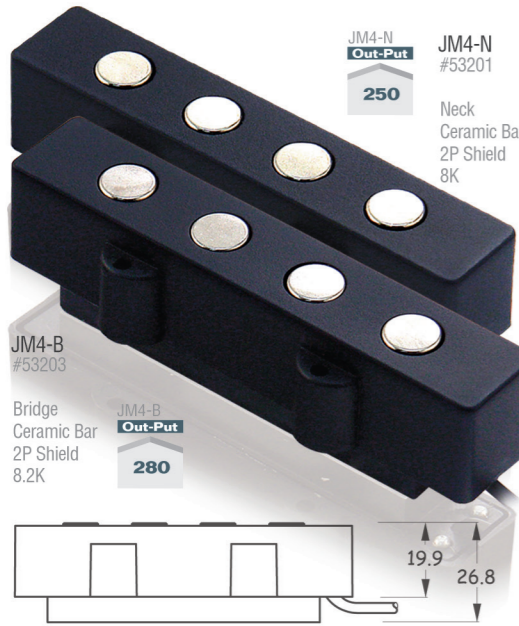

JM4-B
#53203

Bridge
Ceramic Bar
2P Shield
8.2K

JM4-B
Out-Put
280

JM4-N
Out-Put
250

JM4-N
#53201
Neck
Ceramic Bar
2P Shield
8K

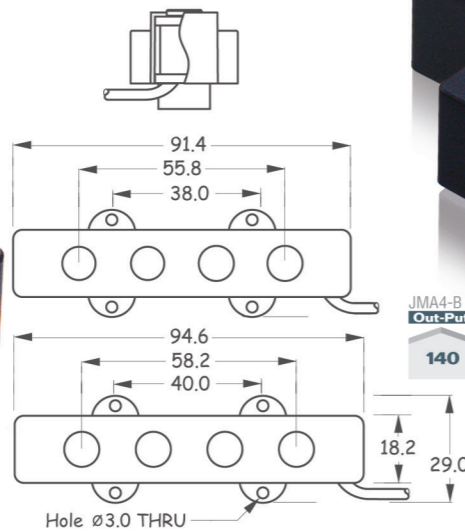

JMA4-N
Out-Put
140

JMA4-N
#53501
Neck
Alnico 5 Rods
2P shield
8K

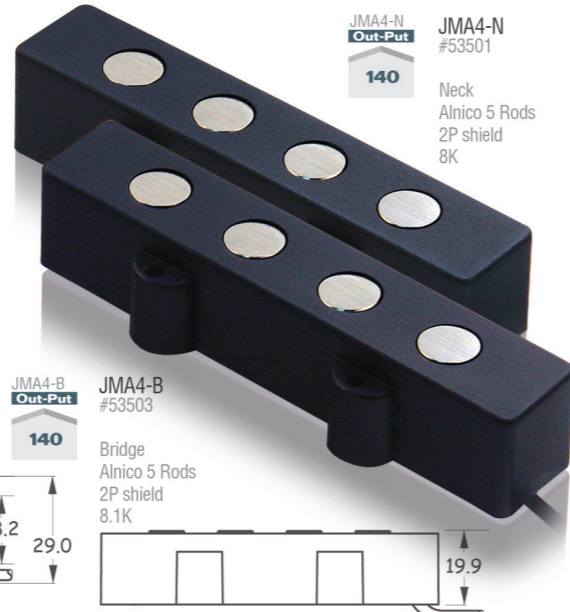

JMA4-B
#53503

Bridge
Alnico 5 Rods
2P shield
8.1K

JMA4-B
Out-Put
140

JMA4

JM4 has high output and more clean and powerful tone by Alnico 5. The extra big diameter pole pieces and over wound coils give you maximum sharper attack and more punch in the bass response.

JV8

JV8 pickup features the flat Alnico 5 rod magnets with 0.187 inch diameter narrowed. This resulted in "a more focused magnetic field under the string and subsequently a brighter and tighter tone.

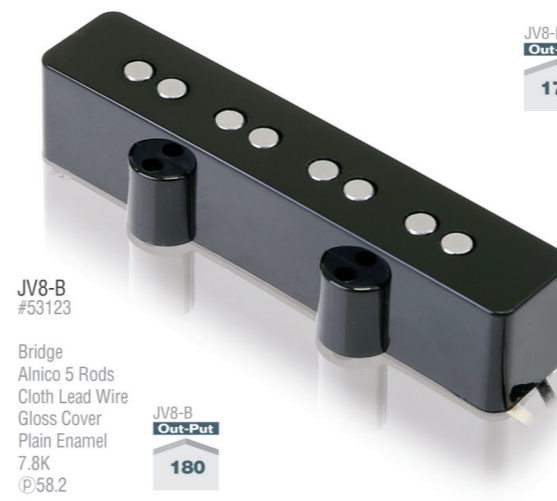

JV8-B
#53123

Bridge
Alnico 5 Rods
Cloth Lead Wire
Gloss Cover
Plain Enamel
7.8K
©58.2

JV8-B
Out-Put
180

JV8-N
Out-Put
170

JV8-N
#53121
Neck
Alnico 5 Rods
Cloth Lead Wire
Gloss Cover
Plain Enamel
7.6K
©55.8

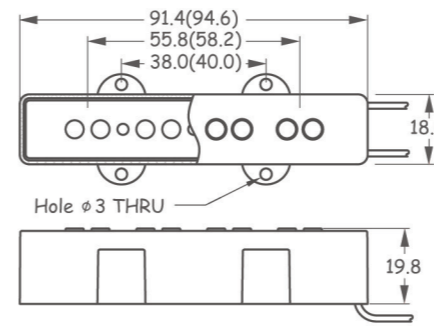

JSP4

JSP4 features a split coil humbucking design. It is designed to have a tone as close as possible to a true single coil.



JSP4-B
#53173

Bridge
Alnico 3&5 Rods
2P Shield
7.9K
©58.2

JSP4-B
Out-Put
180

JSP4-N
Out-Put
180

JSP4-N
#53171
Neck
Alnico 3&5 Rods
2P Shield
7.9K
©55.8

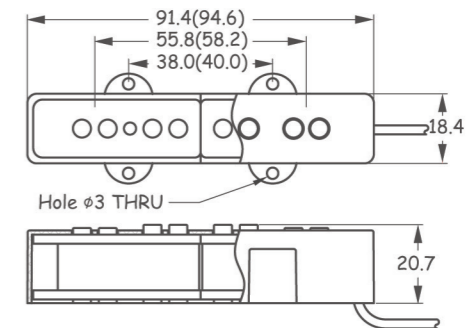

JBZ

This is contemporary active pickup for 4-string Jazz Bass®. It provides a modern, broad tonal response that's perfect for a Jazz Bass® style, but without the brittleness found in other active pickups. Available as any individual Jazz Bass® replacement bridge pickup, in a neck and bridge Jazz Bass set, and in a P-J configuration, ceramic magnets with epoxy sealed.

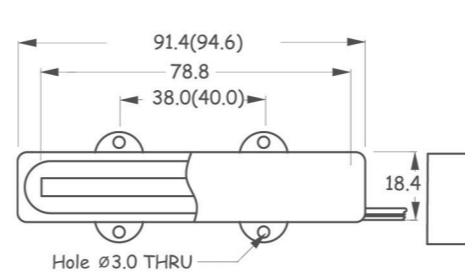

JBZ-B
Out-Put
280

JBZ-B
#53403
Bridge
Ceramic Bar
1P Teflon Wire
5.4K

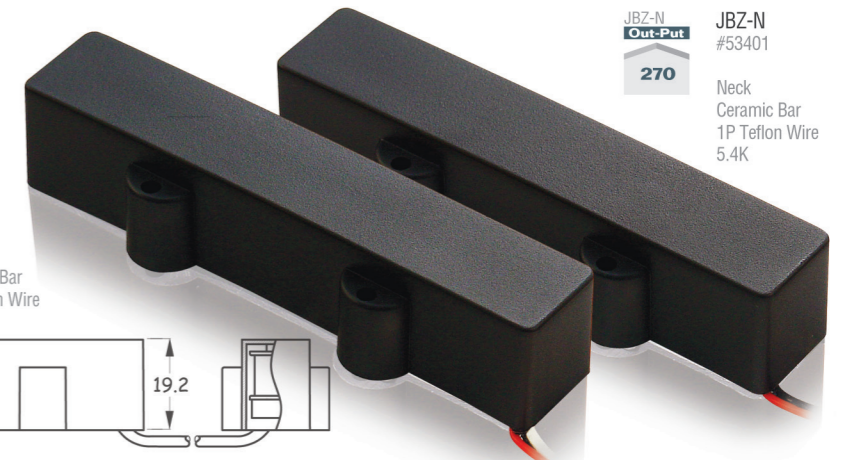

JBZ-N
Out-Put
270

JBZ-N
#53401
Neck
Ceramic Bar
1P Teflon Wire
5.4K

MJB

It is 4-string Jazz Bass® passive pickup. It provides a modern, broad tonal response that's perfect for a Jazz Bass®, but without the brittleness found in other active pickups. Available as any individual Jazz Bass® replacement bridge pickup, in a neck and bridge Jazz Bass® style set, and in a P-J configuration, ceramic magnets with epoxy sealed.

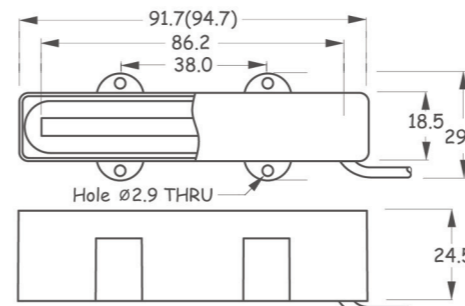

MJB-B
Out-Put
120

MJB-B
#53303
Bridge
Ceramic Bar
1P Shield
7.3K

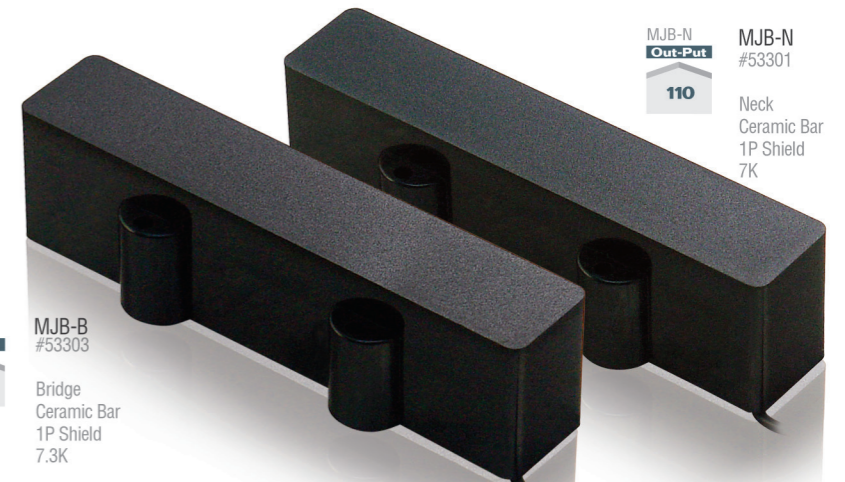

MJB-N
Out-Put
110

MJB-N
#53301
Neck
Ceramic Bar
1P Shield
7K

JA50

JA50 is the most represented 5-string J-Bass style pickup of WSC. The 67mm(neck) and 70mm(bridge) is a direct retrofit for Fende Jazz V®. Traditional single coil pickup for 5-string. Great for country, pop, blues, and classic rock. It delivers '60s Jazz Bass® tone, and it is constructed with Alnico 5 magnets.

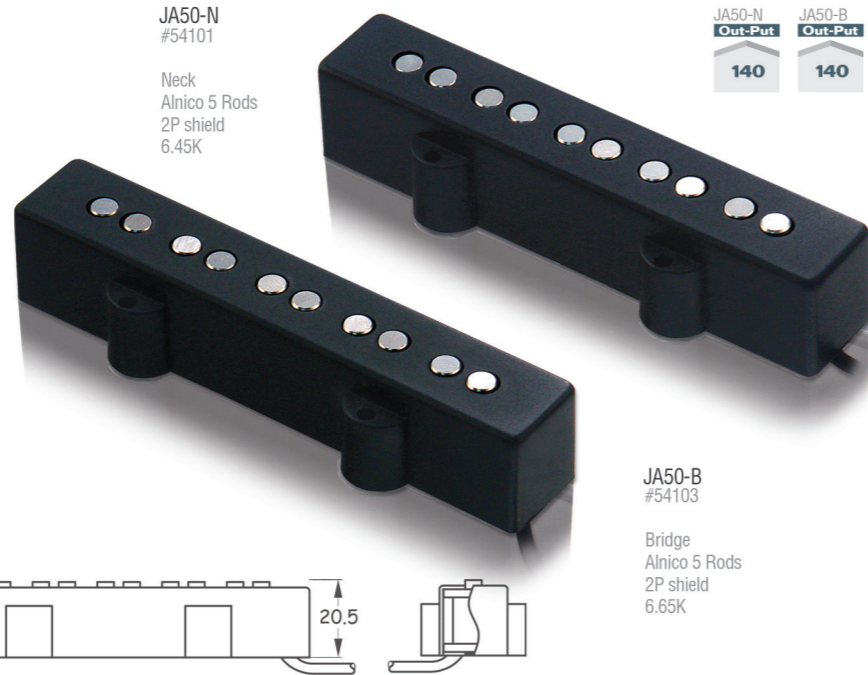
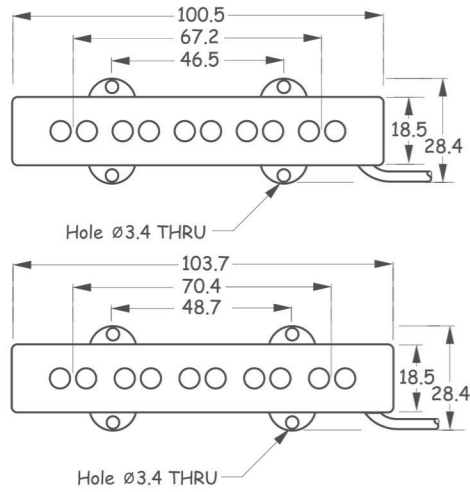

JB59

JB59 is epoxy sealed, 5-string unexposed J-Bass® style pickup with ceramic 8 bar magnets and rounded edge cover. The tone is more modern with sharper attack and more punch in the bass response.

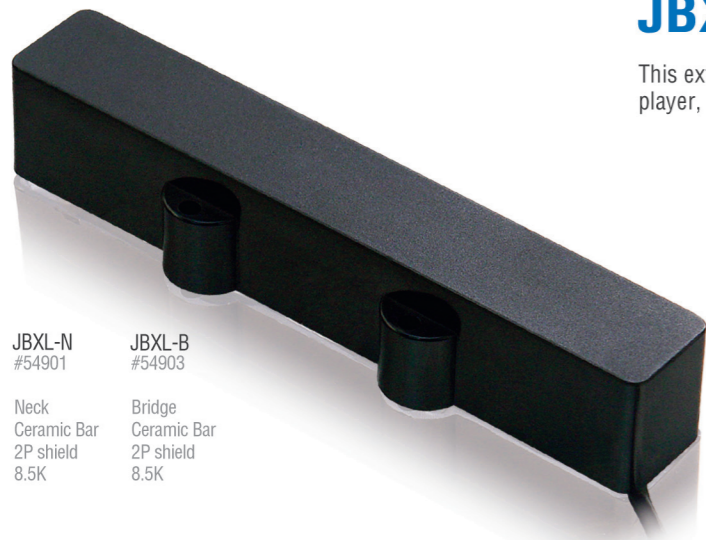
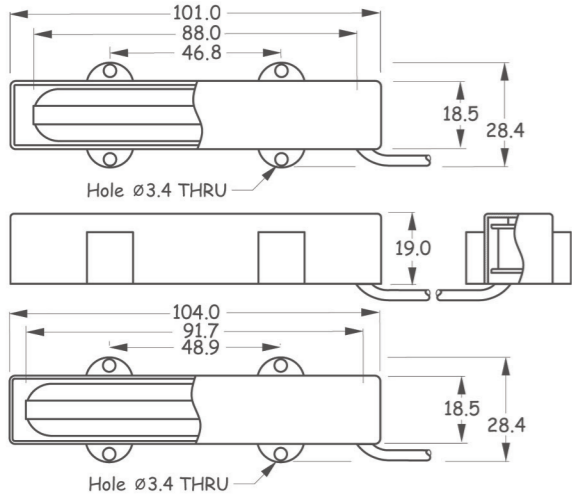

JBXL

This extra long Jazz Bass style pickup is designed for the custom 5-string or 6-string player, with ceramic 8 magnets and two splits bobbins.

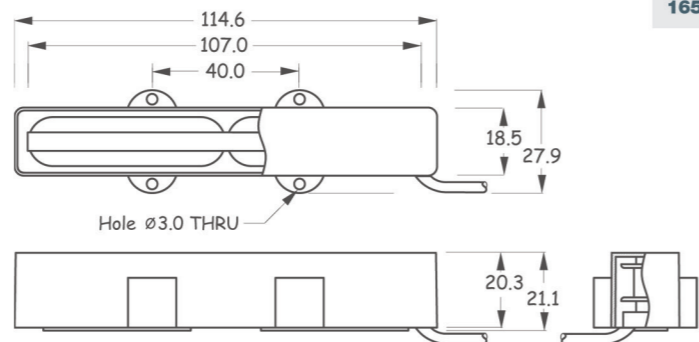

JM5

JM5 has high output and more powerful tone by ceramic magnet. The extra big diameter pole pieces which is pure 1010 and over wound coils give you maximum output and a full frequency response. Recommended for heavy metal and rock, classic metal.

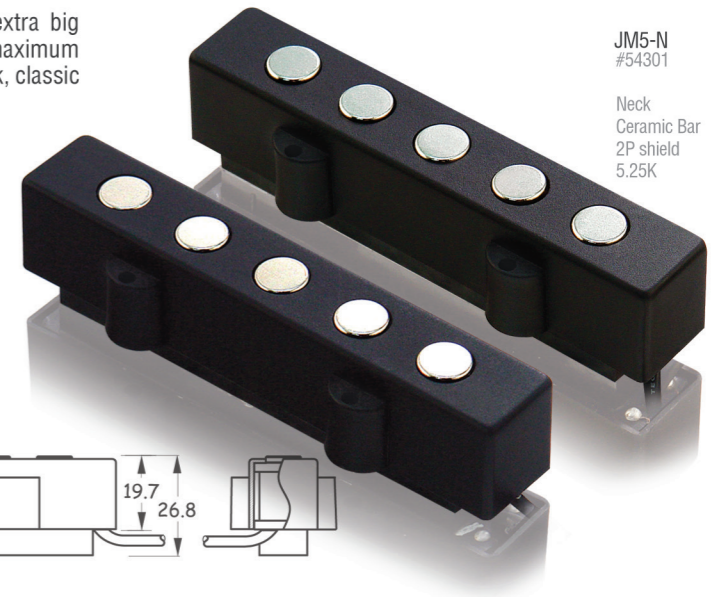
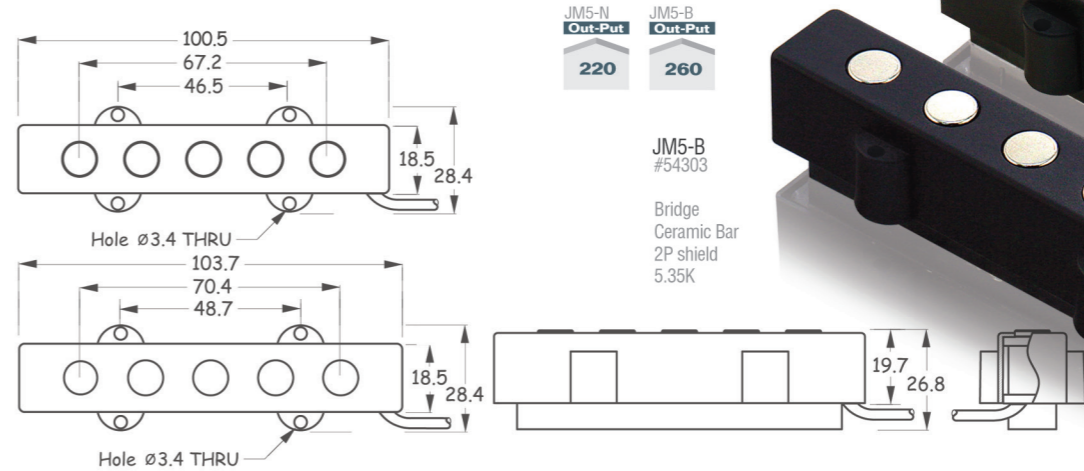

JHR

JHR offers the same great tone of J-Bass® pickups, furthermore, the two hot rails response more hotter and powerful tone. Like other J-bass pickups, JHR also delivers quite performance. This pickup is a direct retrofit for Fender Jazz V® and many other popular 5-string basses.

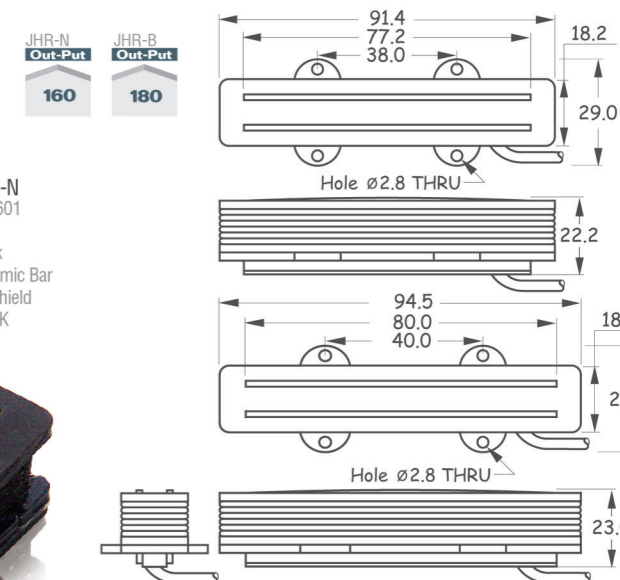
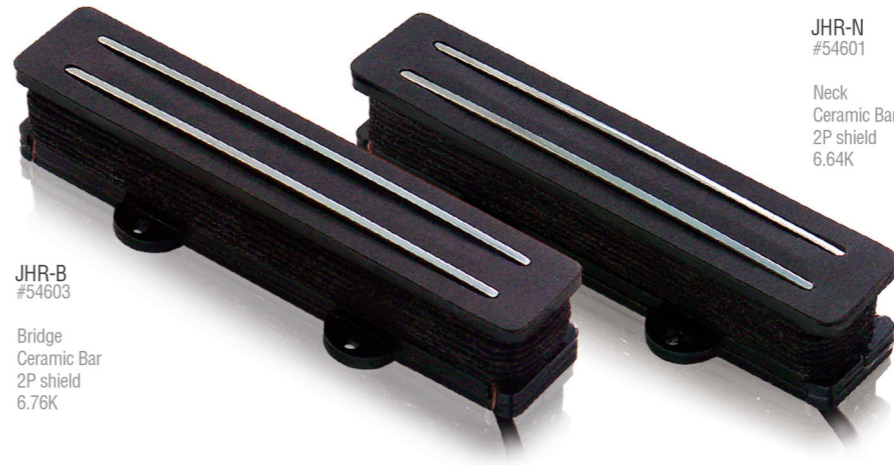

MA4

The Music Man® style pickup with the Alnico 5 extra big magnets, together with unique coil grounding, have the effect of extending both ends of the frequency spectrum beyond that of the ceramic magnet version. In other words, the Alnico version is both warmer on the bottom and more detailed on top.

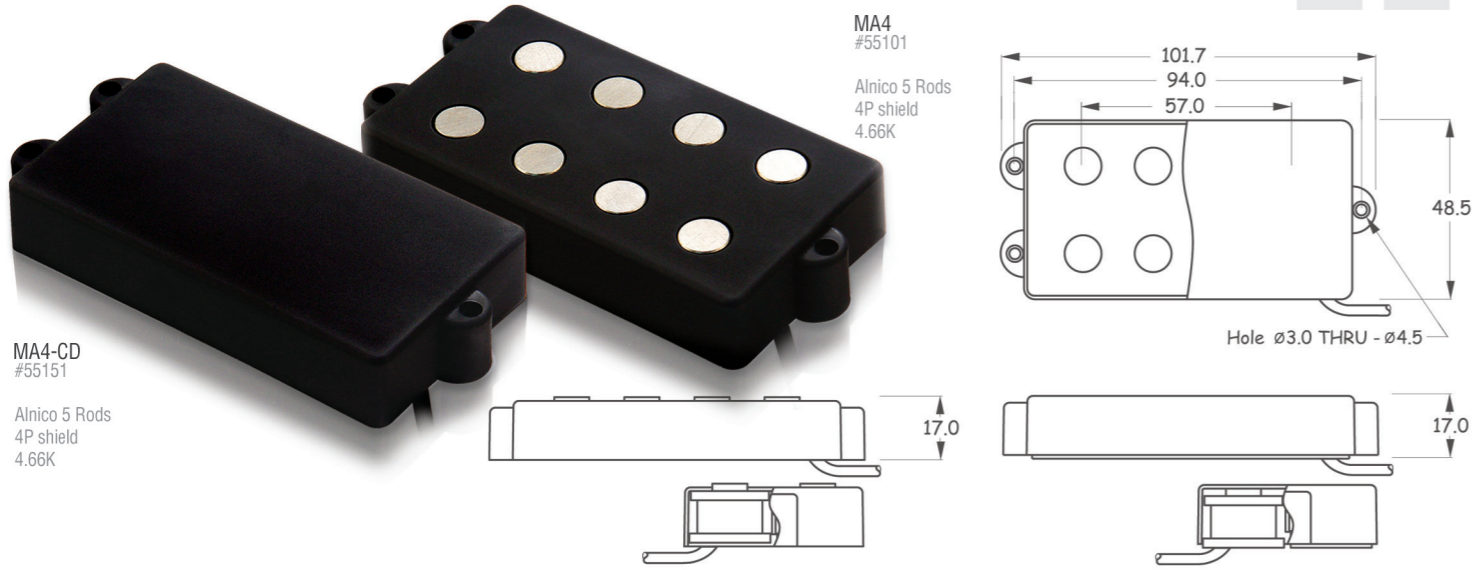

MA5

5-string Music Man® style pickup with the Alnico 5 extra big magnets, together with unique coil grounding, have the effect of extending both ends of the frequency spectrum beyond that of the ceramic magnet version. In other words, the Alnico version is both warmer on the bottom and more detailed on top.

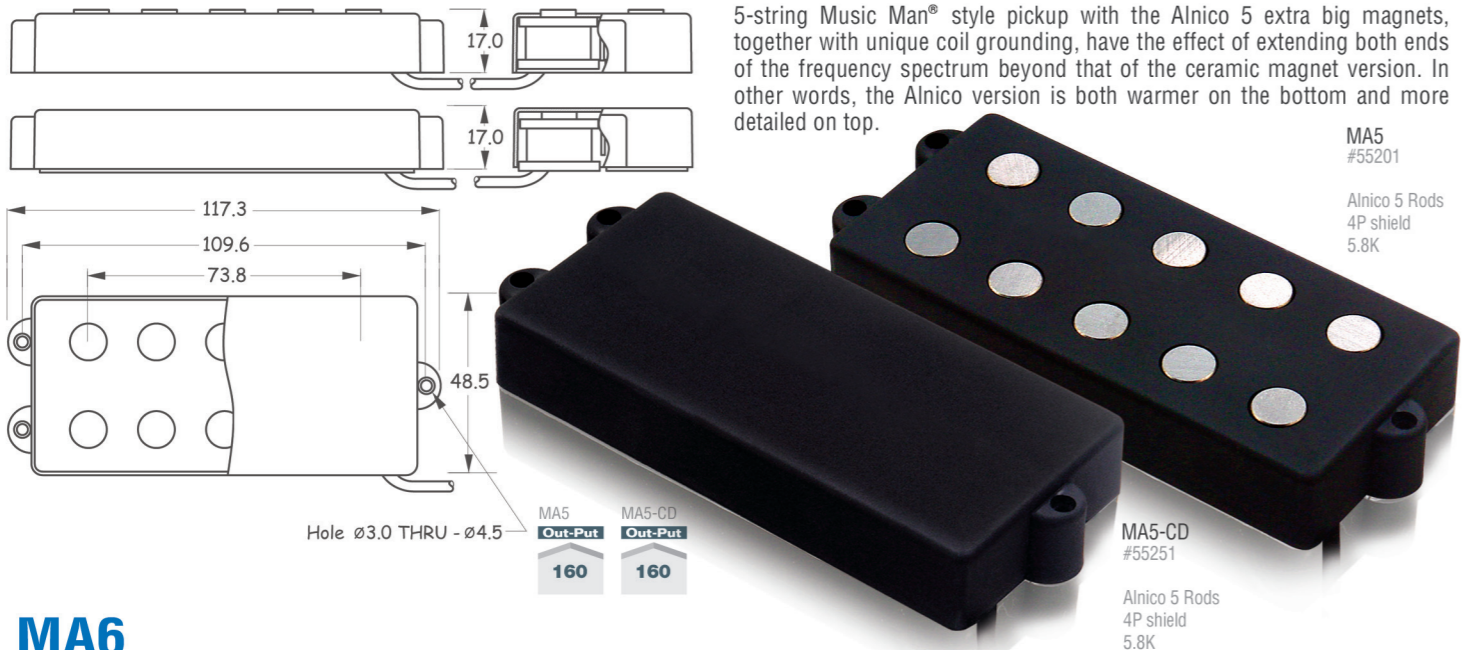

MA6

6-string Music Man® style pickup with the Alnico5 extra big magnets, together with unique coil grounding, have the effect of extending both ends of the frequency spectrum beyond that of the ceramic magnet version. In other words, the Alnico version is both warmer on the bottom and more detailed on top.

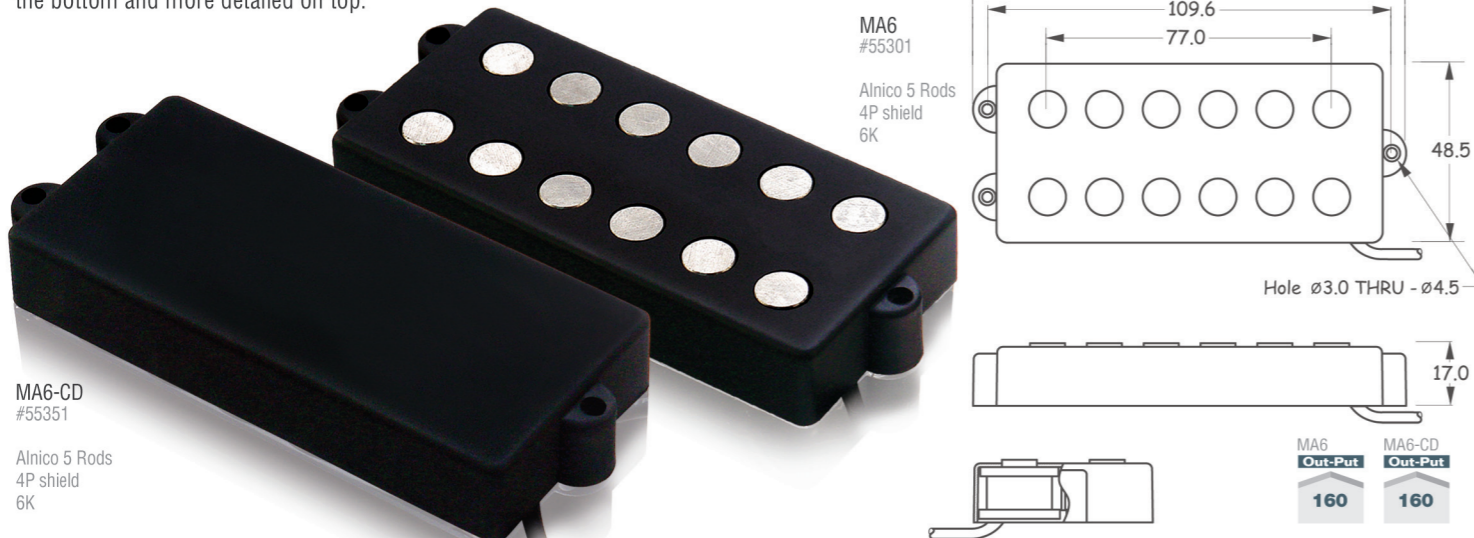

MFR

MFR is 4-string Music Man® style pickup with the ceramic magnets with extra big poles, together with unique coil grounding, have the effect of extending both ends of the frequency spectrum. In other words, the Alnico version is both warmer on the bottom and more detailed on top.



SFR5

SFR5 uses dual ceramic bar magnets that provide a dynamic and responsive attack that works for all playing styles. This pickup has overtones and sustain in the body. The uniform magnetic field of a bar magnet allows each note to have accurate dynamic response and more harmonic.

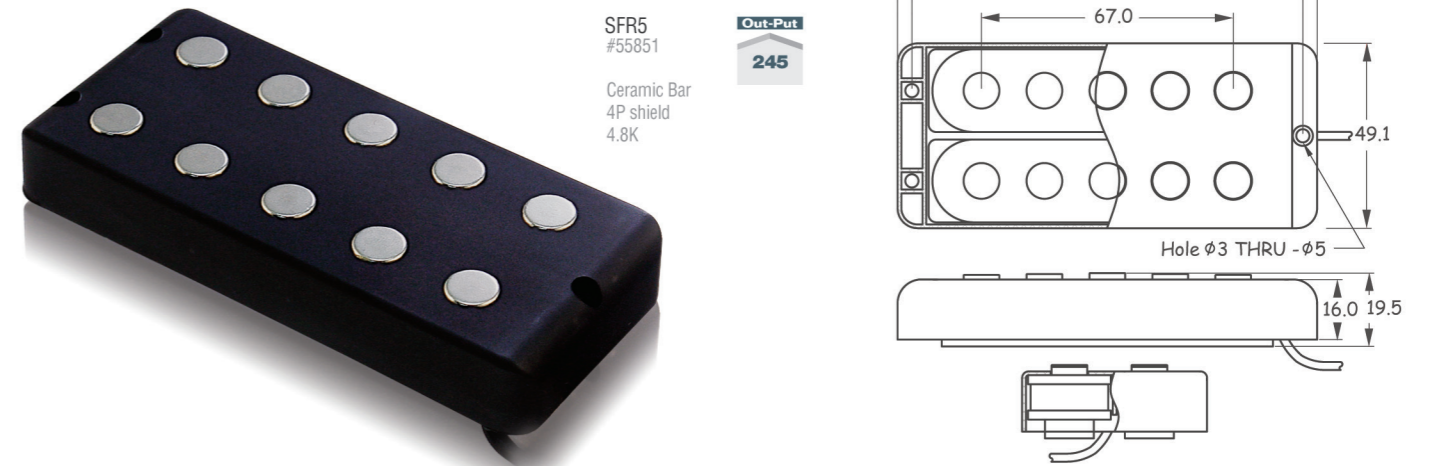

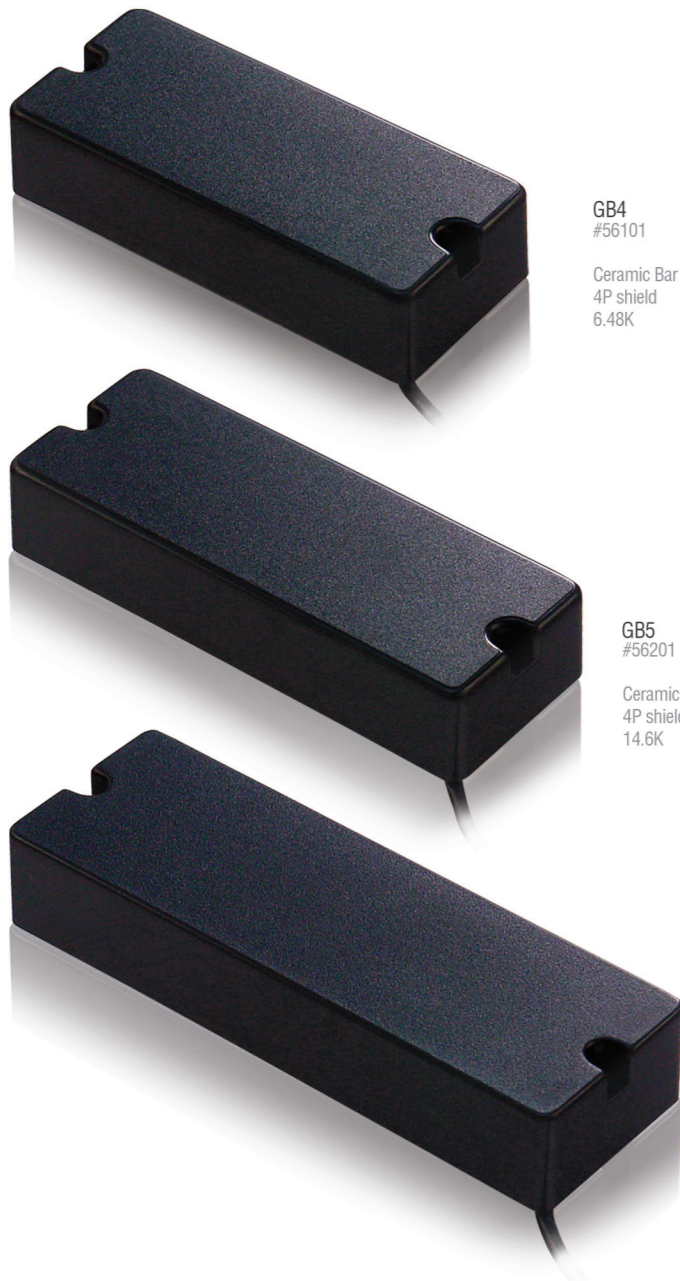

GB

These GB models for 4,5 and 6-string are passive pickup features a humbucker design for low noise and plenty of output, these pickups have the punch and fullness of older passive designs along with added brightness for a better defined tone. These have solid bar poles that cover the entire width of the strings so any string layout can be used. String grounding is recommended to further decrease noise.

GB4
#56101
Ceramic Bar
4P shield
6.48K

GB4	Out-Put
165	
GB5	Out-Put
210	
GB6	Out-Put
195	

GB5
#56201
Ceramic Bar
4P shield
14.6K

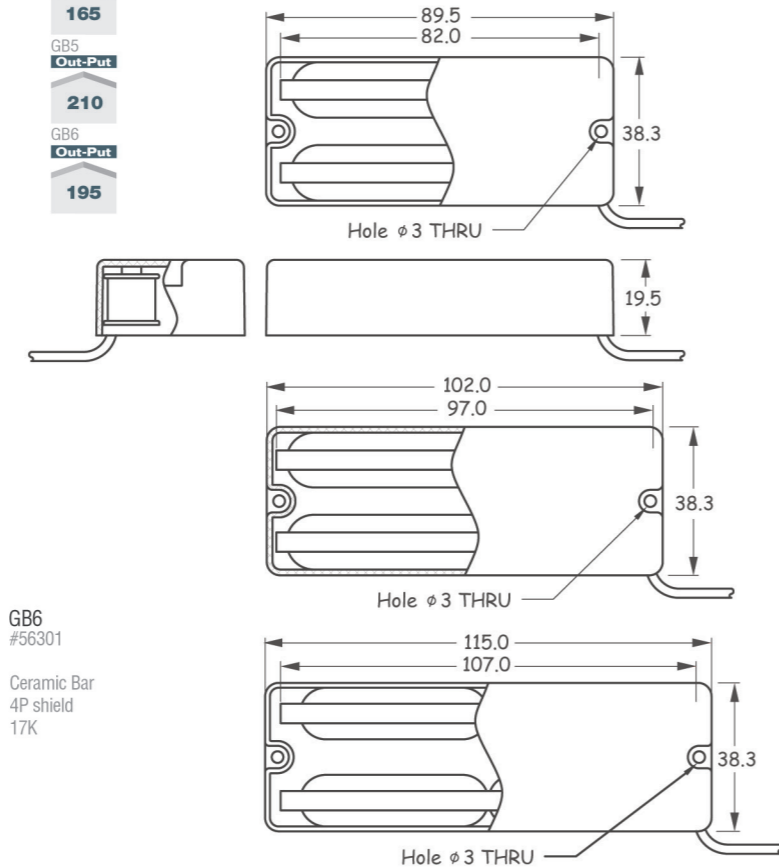

GB6
#56301
Ceramic Bar
4P shield
17K

BT

Traditional soapbar basses (4, 5 and 6 strings) are one of the best sellers passive humbucker pickup. It has a side by side coil configuration designed to enhance mid-range growl while providing a smooth bottom end and clearly defined highs. The tone is traditionally voiced and warm with a detailed and natural high end.

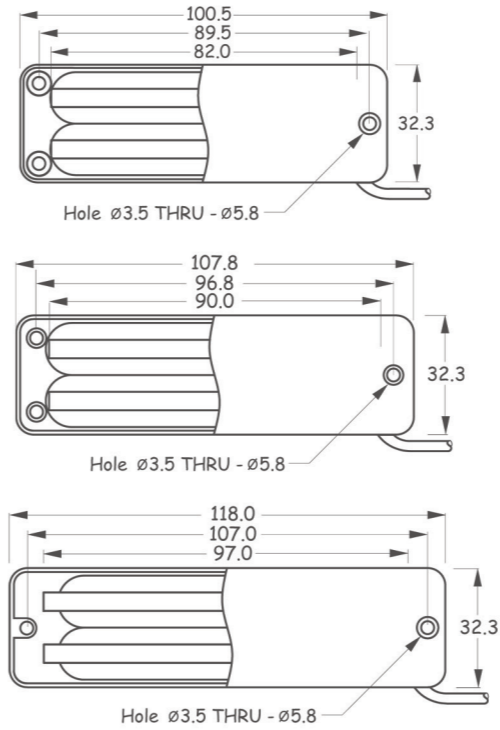

BT4	Out-Put
185	
BT5	Out-Put
220	
BT6	Out-Put
235	

BT40
#57101
Ceramic Bar
2P shield
6.48K

BT50
#57201
Ceramic Bar
2P shield
14K

BT60
#57301
Ceramic Bar
2P shield
14.6K



BTZ Active

BTZ is same as BT model (4, 5 and 6 strings) but active humbucker pickup. Battery life is approximately 1,000 continuous hours per set. It has a side by side coil configuration designed to enhance mid-range growl while providing a smooth bottom end and clearly defined highs. The tone is traditionally voiced and warm with a detailed and natural high end.

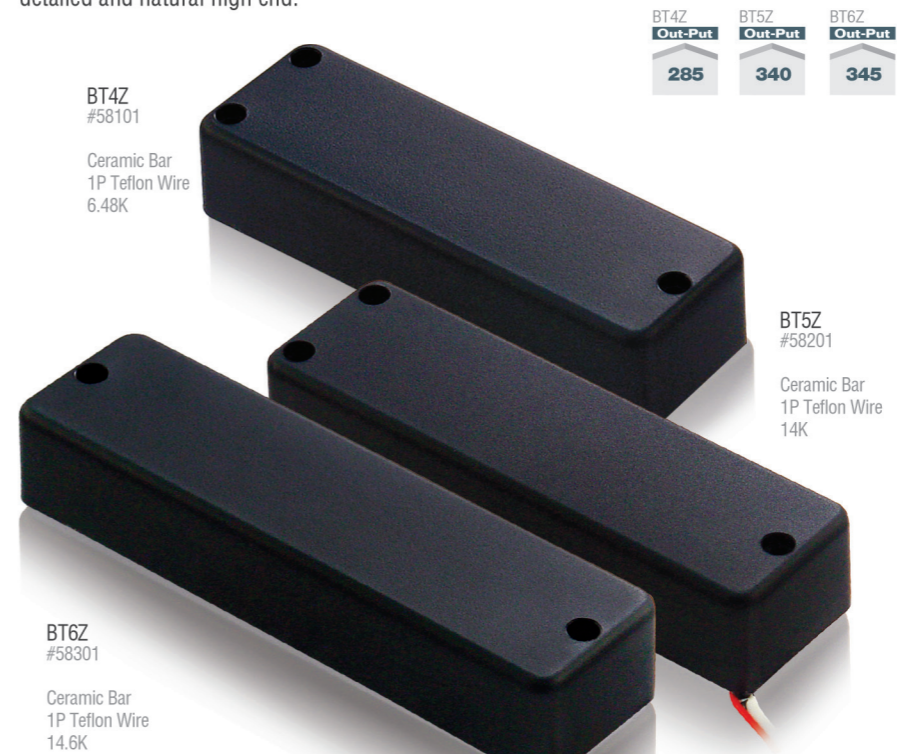

BT4Z	Out-Put	BT5Z	Out-Put	BT6Z	Out-Put
285		340		345	

BT4Z
#58101
Ceramic Bar
1P Teflon Wire
6.48K

BT5Z
#58201
Ceramic Bar
1P Teflon Wire
14K

BT6Z
#58301
Ceramic Bar
1P Teflon Wire
14.6K



BTT

This modern designed bass pickup has a lovely warm, poppy sound with a nice top end, balancing out the fat nature of the humbucker very well, it is available in 4 and 5 string version.

Out-Put
180

BTT4
#59101
Ceramic Bar
4P Shield
6.48K

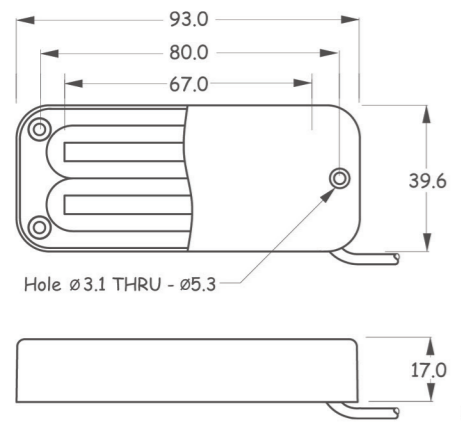
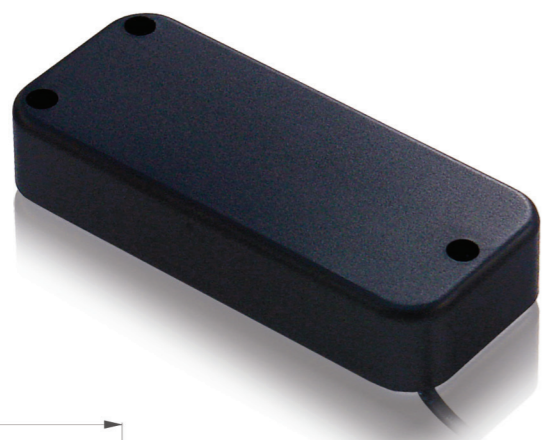

WB2-N
Out-Put
220

WB2-B
Out-Put
220

WB2-N
#59001
Neck
Ceramic Bar
4P Shield
14K
#59003
Bridge

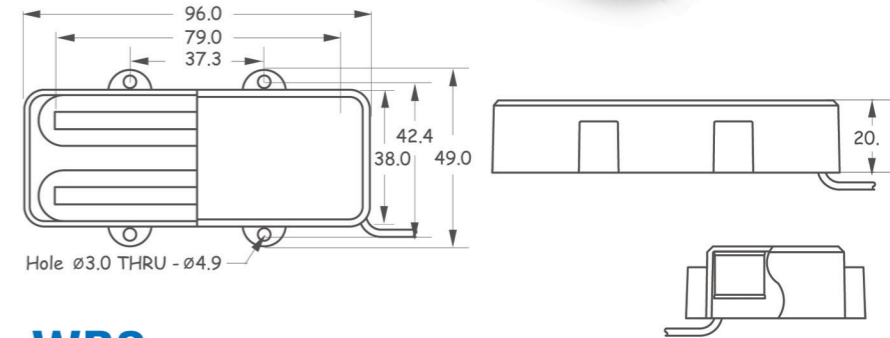

WB2

WB2 has moderate output, passive 'soapbar' pickup for four-or-five-string bass. The tone is simple and organic, with added warmth and punch.

BL

BL model is a contemporary styled soapbar pickup designed with modern jazz style basses in mind. It is completely sealed humbucker pickup that is durable and sounds brilliant. Also designed to fit new American contemporary basses such as Music Man® basses etc.

BL5
Out-Put
220

BL6
Out-Put
235

BL5
#59601
Ceramic Bar
2P Shield
14K

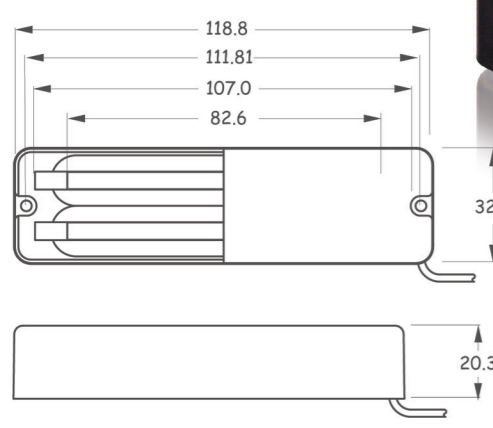
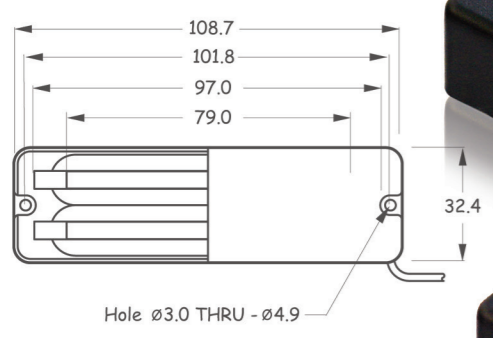

BL6
#59701
Ceramic Bar
2P Shield
14.6K

SW

This SW series 'stickbar' humbucker pickups have a deep smooth bass response with excellent mid range punch and top end definition. SW45 is good for 4 and 5 string bass, SW56 is for the 5 and 6 string basses with ceramic manets and epoxy finished.

SW45
#59301
Ceramic Bar
4P Shield
14.7K
Out-Put
240

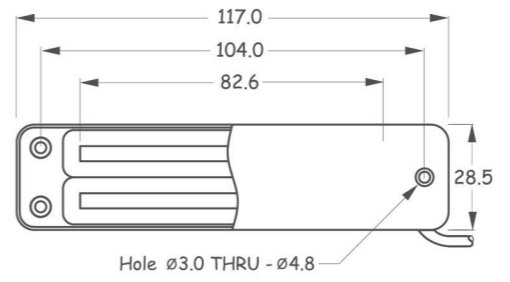
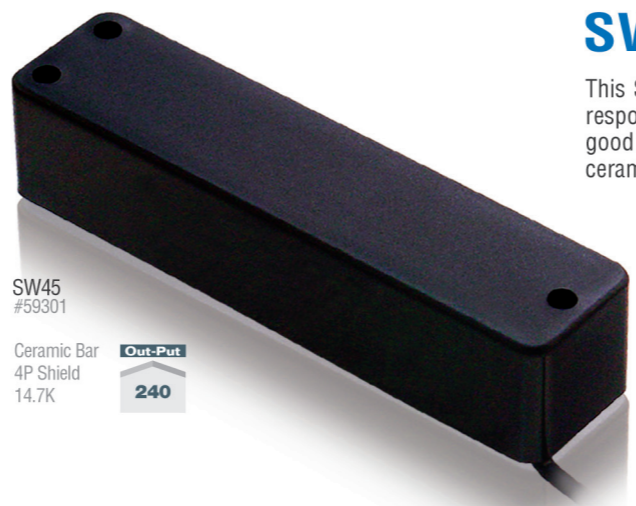

SW56
#59401
Ceramic Bar
4P Shield
17.64K
Out-Put
245

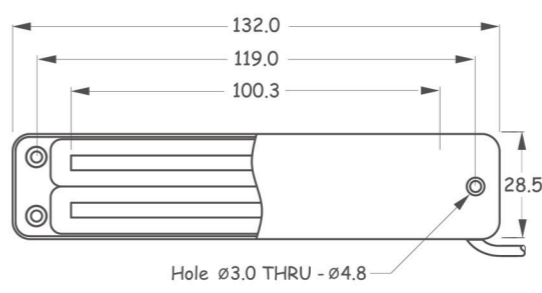
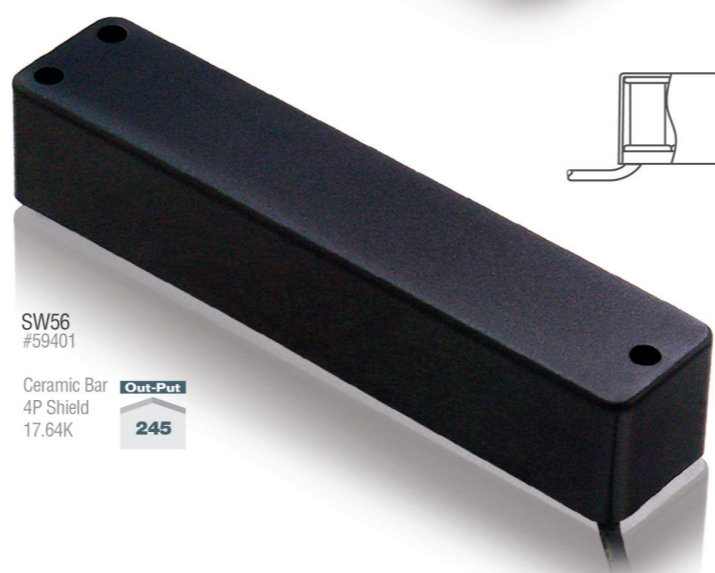



Bass Custom

Music Man® style and modern J-Bass® type pickup combination with the Alnico 5 extra big magnets produces unique tone and sound. Also delivers the punch of a single coil, without hum. Very pleasing, articulate mid-range with no harshness.

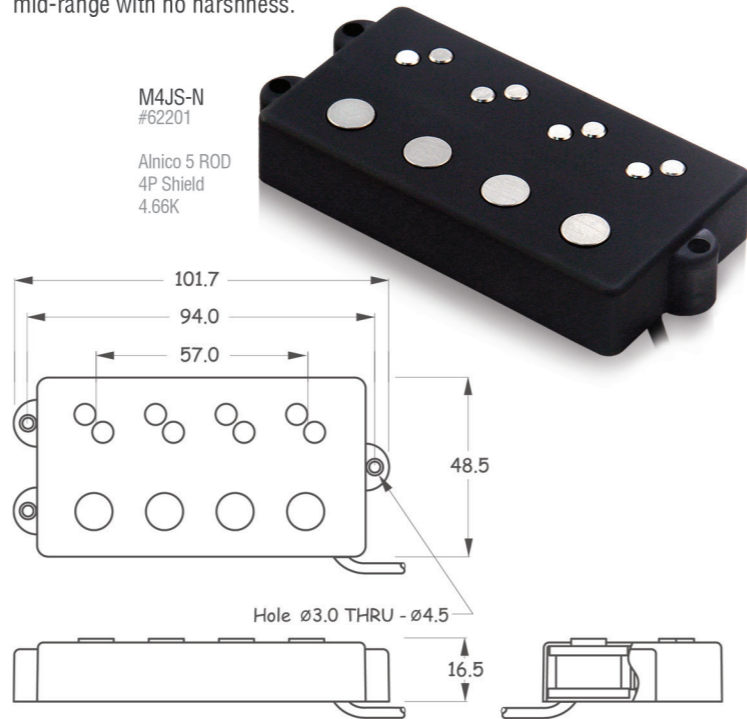

M4JS-N
#62201

Alnico 5 ROD
4P Shield
4.66K

MFPB

The Music Man® style pickup with the Alnico5 extra big magnets and cosmetic cover together with unique coil grounding, have the effect of extending both ends of the frequency spectrum beyond that of the ceramic magnet version. In other words, the Alnico version is both warmer on the bottom and more detailed on top.

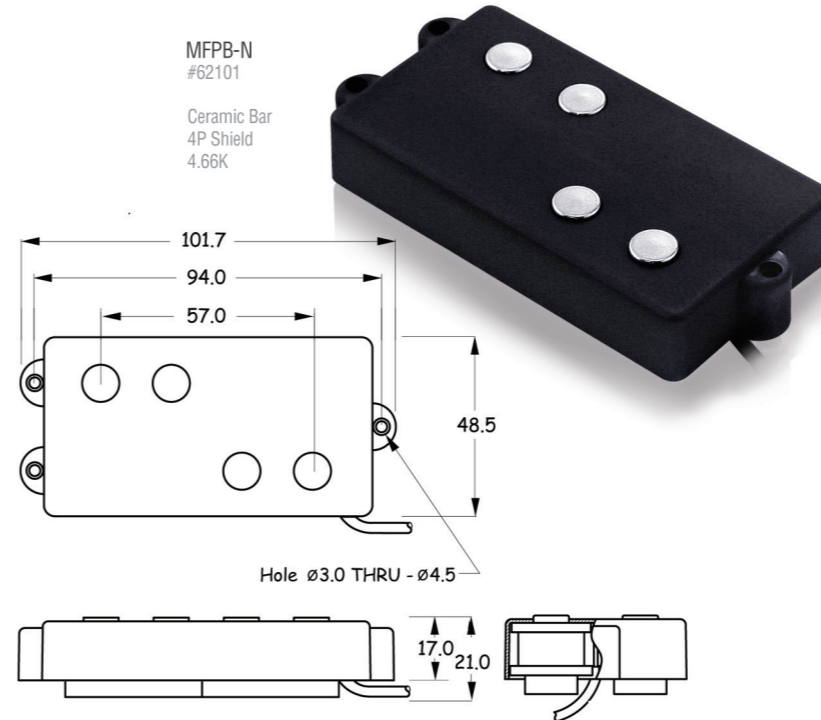

MFPB-N
#62101

Ceramic Bar
4P Shield
4.66K

Wood Cover

Exotic Wooden bass covers for the custom pickups by CNC machine. Available in Ebony, Maple, Mahogany and most of wood for the guitar. Any size and shapes are acceptable.



Dual Jazz Bass

BTJA model is the icon of modern designed humbucker bass pickups. This is designed dual coil humbucker with using Alnico 5 magnets and the traditional bi-pole layout with two poles per string. It's almost like two Jazz Bass® style pickups.



BTJA4-B
#61103

Bridge
Alnico 5 Rods
4P Shield
17.4K

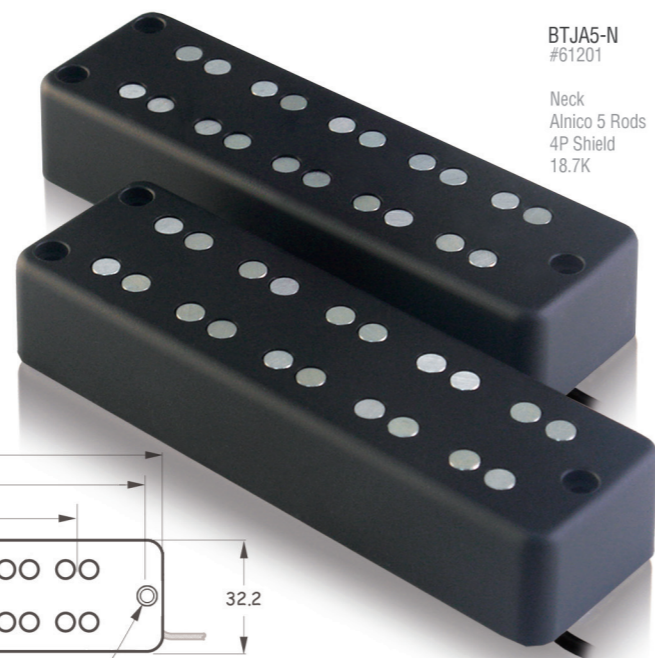
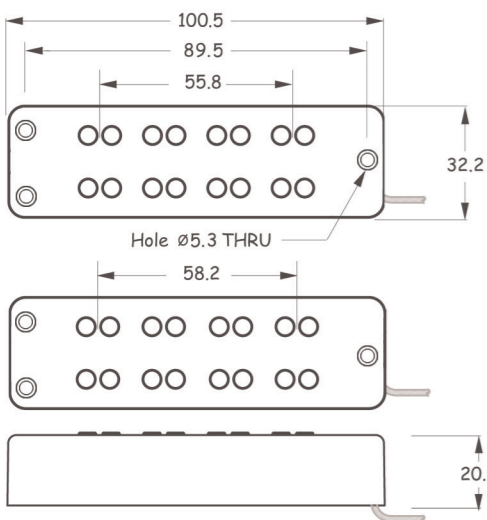

BTJA5-N
#61201

Neck
Alnico 5 Rods
4P Shield
18.7K

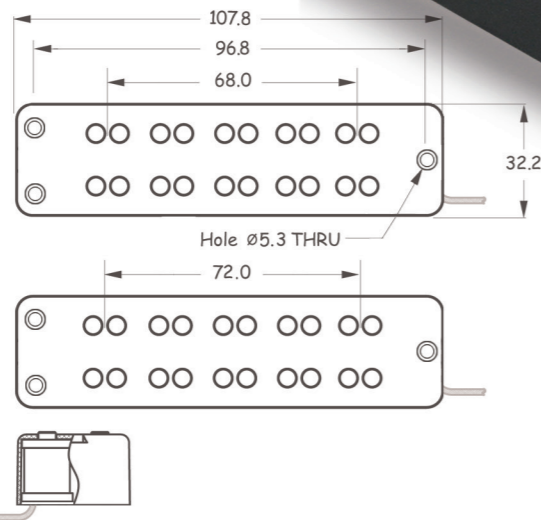

BTJA5-B
#61203

Neck
Alnico 5 Rods
4P Shield
20.4K

QJB

QJB is 4-string single-coil bass pickup with neck and bridge combination and none covered. The wider pole distance and ceramic magnets provides full passive response that exhibits deep, strong, low end properties with extended high end and brightness.

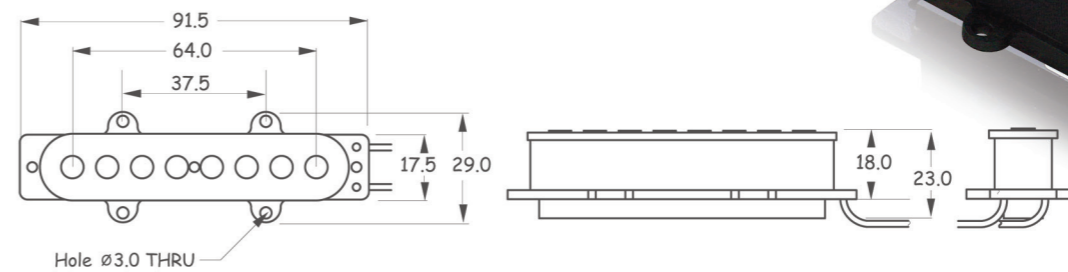

QJB-N
#67601

Neck
Ceramic Bar
Flex PVC
7.6K

#67602
Center
#67603
Bridge

QJA

QJA is also 4-string single-coil J-Bass style pickup with the Alnico 5 extra big magnets, have the effect of extending both ends of the frequency spectrum beyond that of the ceramic magnets version. In other words, this Alnico version is both warmer on the bottom and more detailed on top compared with QJB.

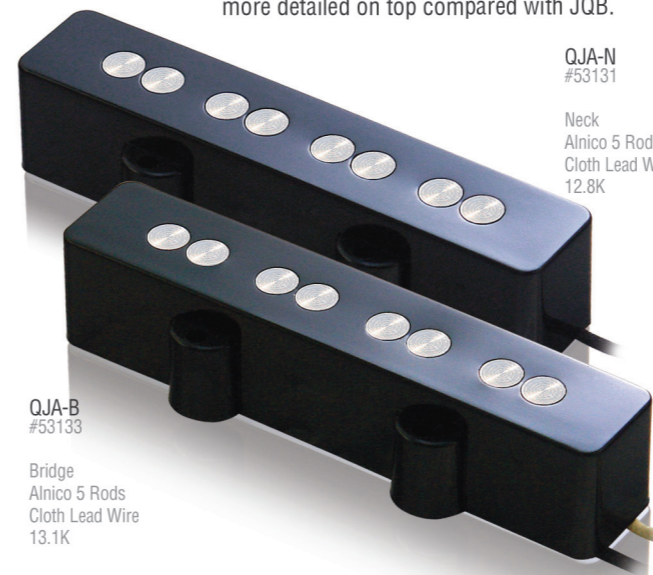

QJA-B
#53133

Bridge
Alnico 5 Rods
Cloth Lead Wire
13.1K

QJA-N
#53131

Neck
Alnico 5 Rods
Cloth Lead Wire
12.8K

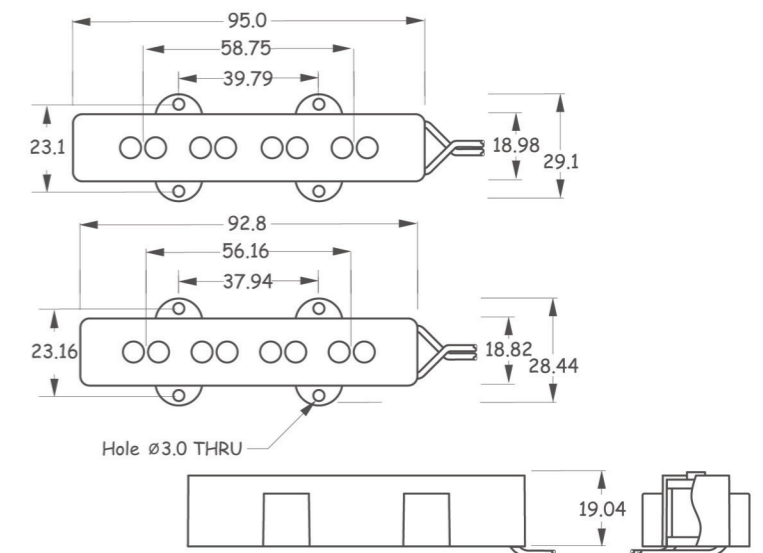

Humbucker Bass

These pickups are one of WSC custom shop pickups, just looks like a humbucker of guitar. These have soild, deep and musical mids, crisp, smooth high. Also have clean powerful passive, works great with any preamp we well.

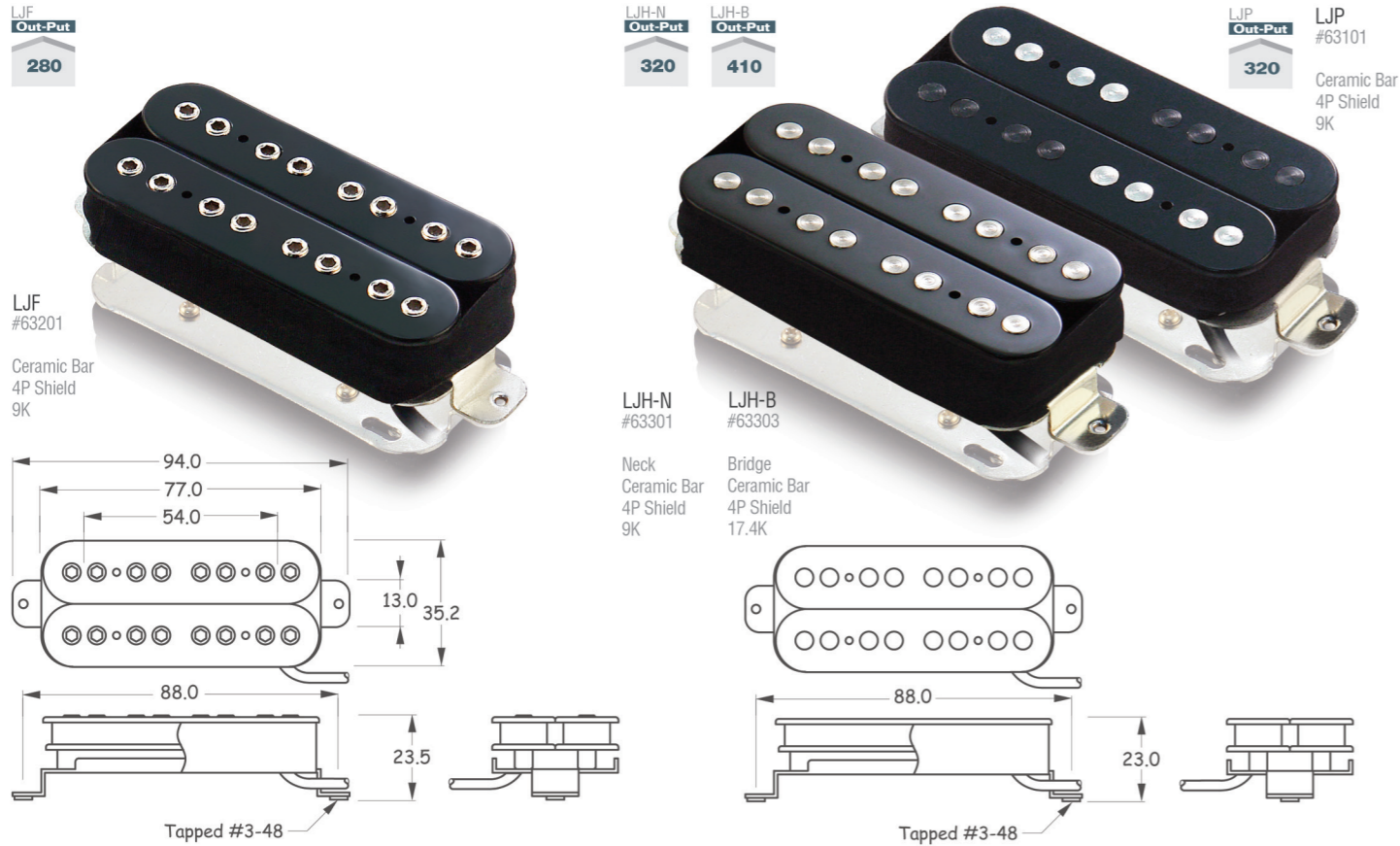

MHBB

This model is Gibson SG®reissue type bass mini humbucker pickup in chrome and other similar bass models.

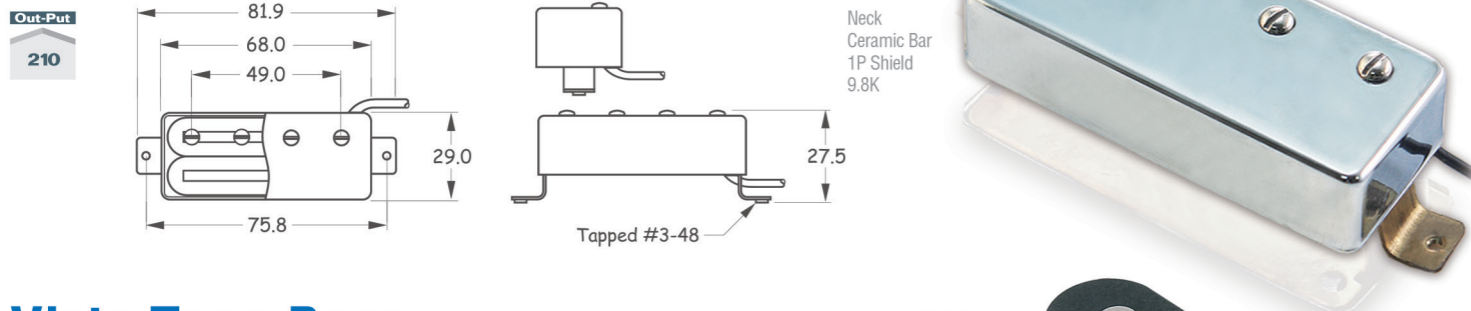

Vista Tone Bass

Big-Poles single coil bass pickups are designed for more sensitive string activities. This means the Big-Pole AL5 magnets delivers more aggressive and accurate tone for the bass guitars. Specially, rich midrange tone and high out puts are good enough for any kind of music genre.

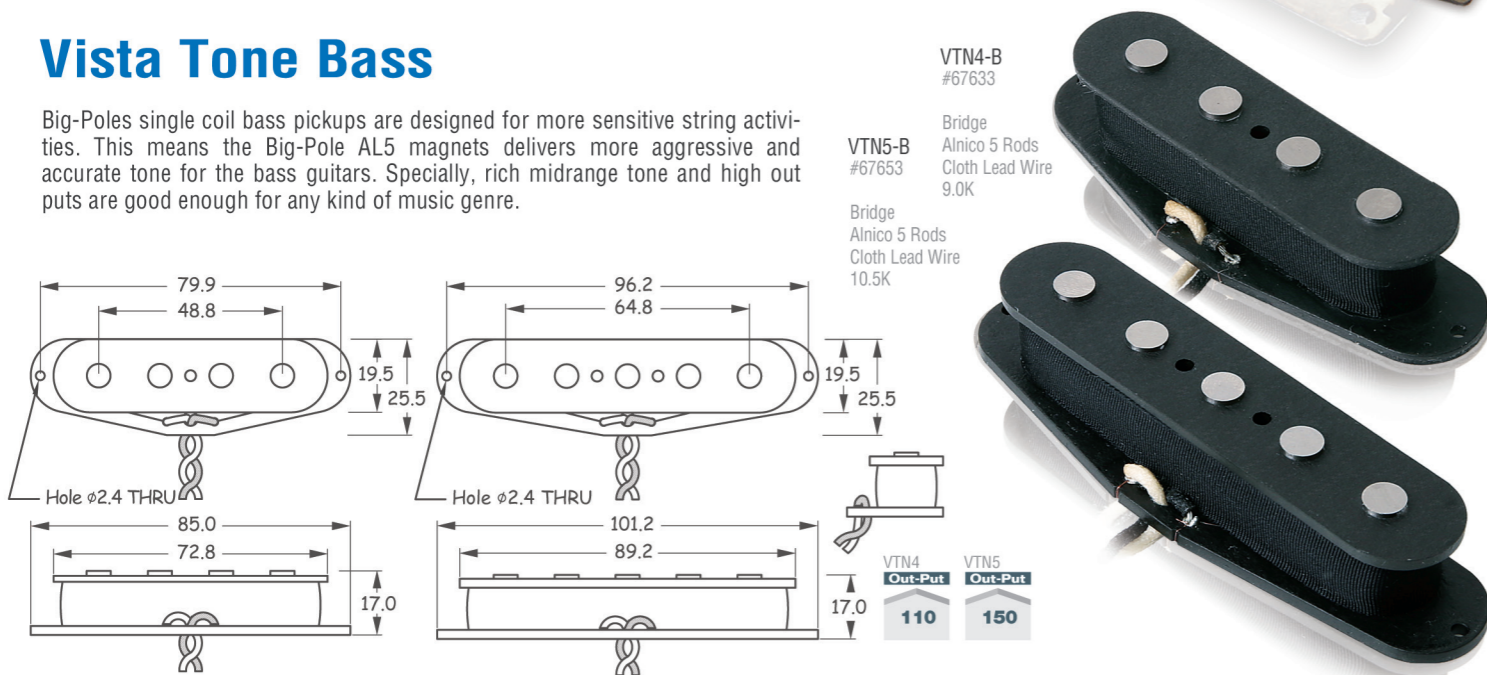

RKB-CR®

Vintage RK® Bass style pickup set, the bridge pickup uses dual ceramic magnets for more power and sustain. The neck pickup uses two ceramic magnets and special windings for fullness and warmth. Both pickups will increase output and expand the tonal range of a stock bass.

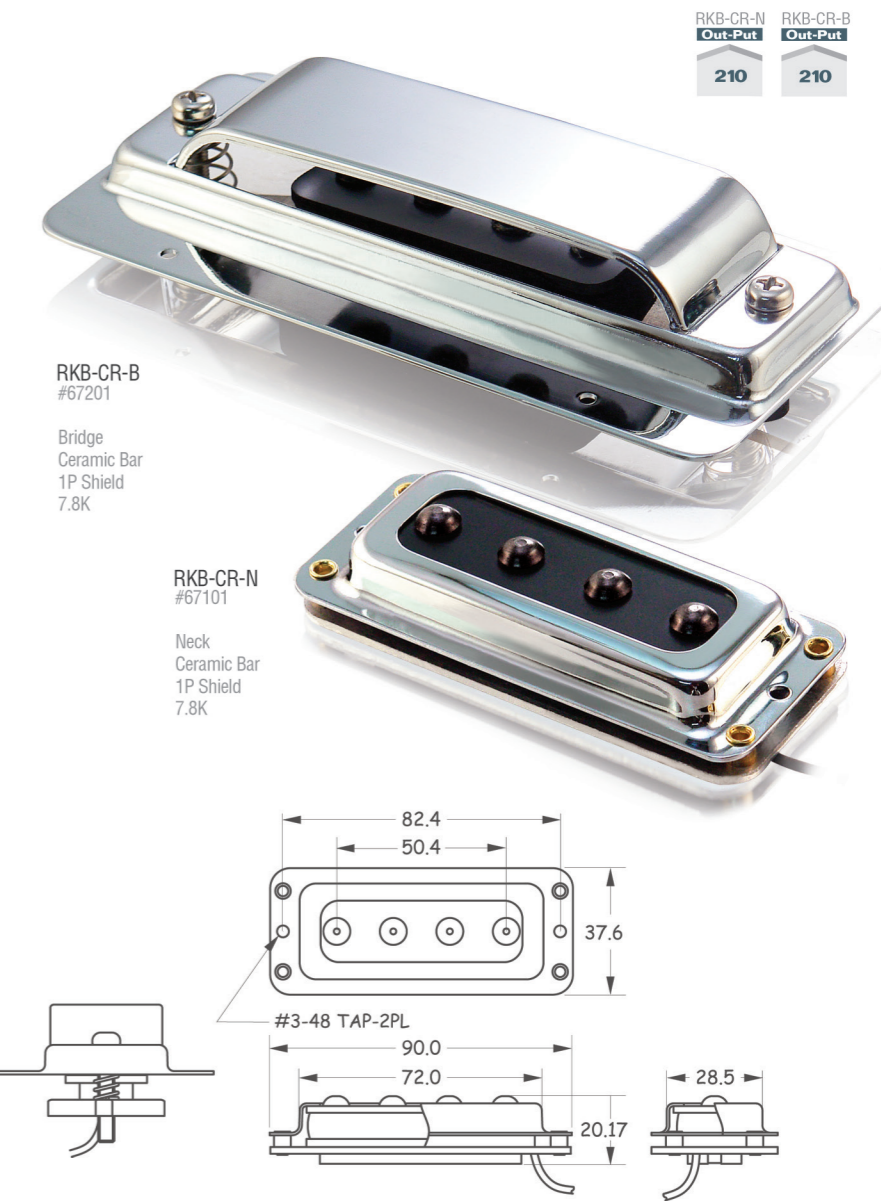

SWB

SWB is vintage Gibson® style bass humbucker pickup with chrome-plated cover, as opposed to the nickel, and is taller yet narrow.

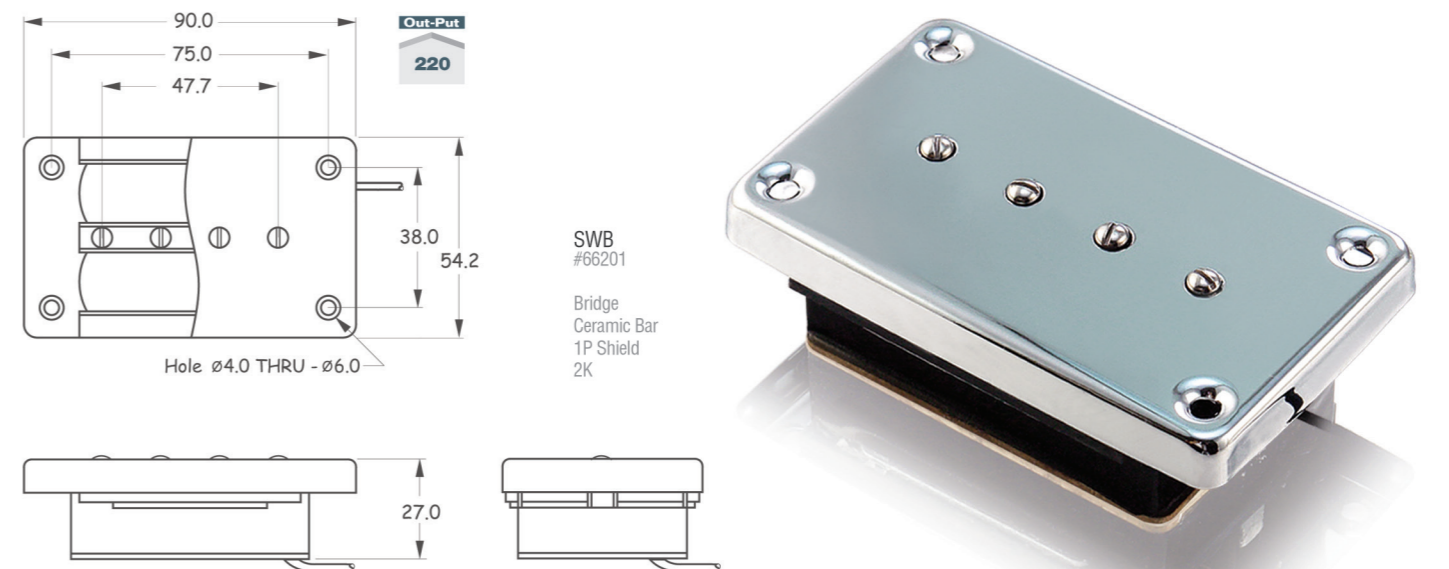

Mounting Rings

Mounting Rings



MT10F
88.7x44.5
2.5x2.5
Flat-top
#7101

Humbucker #980178



MT20F
88.7x44.5
3.55x5.5
Flat-top
#7201

Humbucker #980176



MT30F
92.2x46
3.5x4.8
Flat-top
#7301

Humbucker #980174



MT10R
88.7x44.5
5.0x5.0
Flat-top
#7102

Humbucker #980177



MT20R
88.7x44.5
9.0x10.75
Flat-top
#7202

Humbucker #980175



MT30R
92.2x46
4.6x6.8
Flat-top
#7302

Humbucker #980173

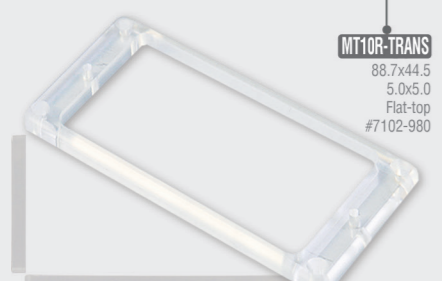

MT10R-TRANS
88.7x44.5
5.0x5.0
Flat-top
#7102-980

Humbucker #980178

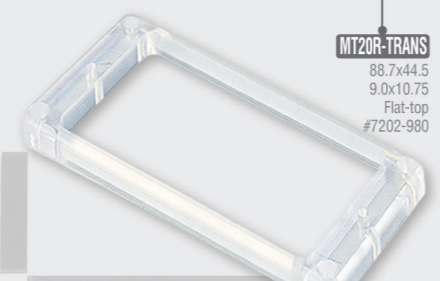

MT20R-TRANS
88.7x44.5
9.0x10.75
Flat-top
#7202-980

Humbucker #980177



MT30ER
92.2x46
7.0x9.0
Flat-top
#7303

Humbucker #980172



FRH-BLK
98.0x44.5
3.48
Flat-top
#7056

Humbucker #2K4445



MHBS
85.6x35.3
(IN 68.8x28.8)
8.5x8.5
Flat-top
#7612

for MHB #214062

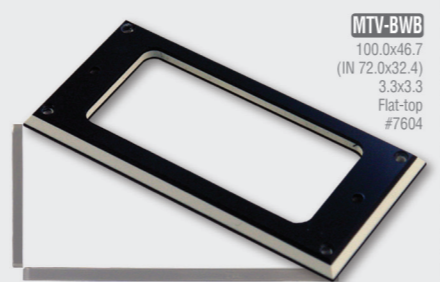

MTV-BWB
100.0x46.7
(IN 72.0x32.4)
3.3x3.3
Flat-top
#7604

for FG #2K6059



FRS-BLK
97.9x37.5
3.48
Flat-top
#7057

for Strat #2K4446



MHBL
85.6x35.3
(IN 68.8x28.8)
16.5x16.5
Flat-top
#7611

for MHB #212234



MHBB-R
93.5x35.0
(IN 68.4x28.3)
12.6x11.4
Flat-top
#7055

for MHBB #210062



MT40F
92.2x46.0
3.7x5.5
Curved
#7401

HB Curved Body #980171



MT70F
97.5x43.0
(IN 79.0x37.2)
5.0x5.0
Flat-top
#7701

HB-7 String #980139



MT80
113.0x45.5
(IN 94.5x39.6)
4.2x4.2
Flat-top
#7800

HB-7 String #212085



MT40R
92.2x46
10.0x11.2
Curved
#7402

HB Curved Body #980170



MT75E
97.5x44.0
(IN 80.5x38.1)
3.6x5.5
Flat-top
#7751

HB-7 String #2K0159

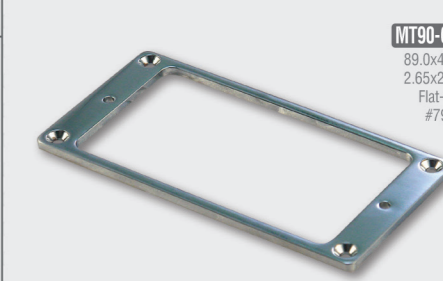

MT90-CR
89.0x45.0
2.65x2.65
Flat-top
#7901

Humbucker #980179



MTTE-CR
100x32.55
2.4x2.4
Flat-top
#7067

Tele #211037



MT75R
97.5x44.0
(IN 80.5x38.1)
9.0x10.8
Flat-top
#7752

HB-7 String #2K0096

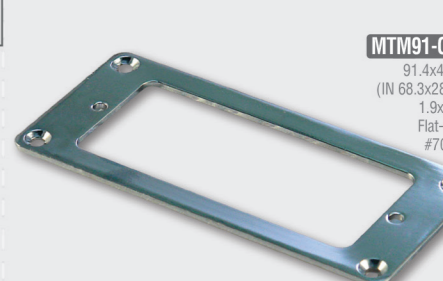

MTM91-CR
91.4x40.8
(IN 68.3x28.5)
1.9x1.9
Flat-top
#7061

for MHB #219129



MTST-CR
100x32.5
2.4x2.4
Flat-top
#7066

for Strat #2K0112

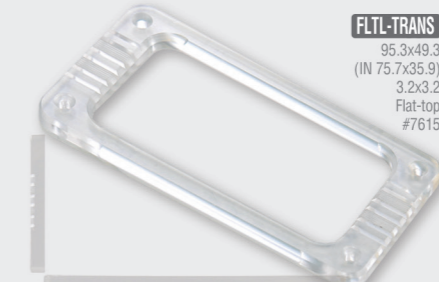

FLTL-TRANS
95.3x49.3
(IN 75.7x35.9)
3.2x3.2
Flat-top
#7615

for FLT #214027

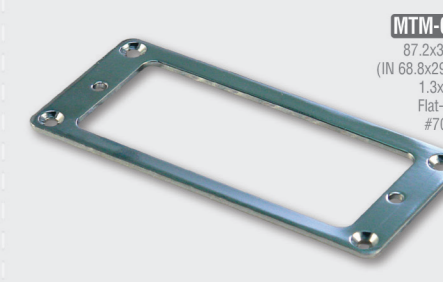

MTM-CR
87.2x38.6
(IN 68.8x29.0)
1.3x1.3
Flat-top
#7058

for MHB #2K0266

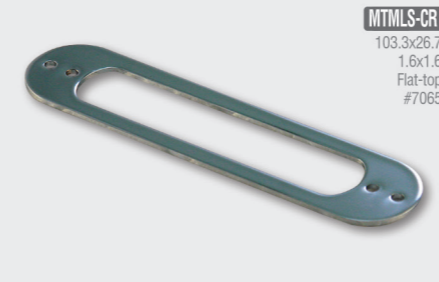

MTMLS-CR
103.3x26.7
1.6x1.6
Flat-top
#7065

for Mini Lipstic #213048



Available custom Rings

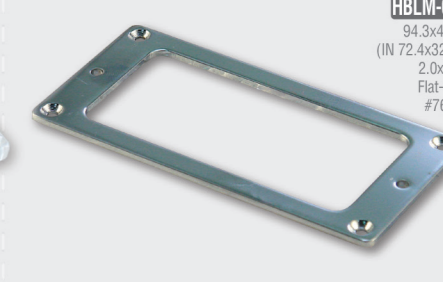

HBLM-CR
94.3x44.0
(IN 72.4x32.4)
2.0x2.0
Flat-top
#7609

for FG #2K0311

Disclaimers: Fender®, Strat®, Stratocaster®, Telecaster®, Tele®, Jazzmaster®, Jaguar®, and Mustang® are registered trademarks of Fender® Musical Instruments. Gibson®, Les Paul®, P-90®, Flying V® are registered trademarks of Gibson Guitar Corp. Music Man® is a registered trademark of Ernie Ball Corp. Rickenbacker® is a registered trademark of Rickenbacker International Corp. WooSung Chorus Industries is not affiliated with these companies.

Screws and Springs for Pickups



	Nickel	Black	Gold
① MO # 6-32x18	#71016	#71010	#71014
② MO # 6-32x20	#71026	#71020	#71024
③ MR # 6-32x18	#71036	#71030	#71034
④ MR # 6-32x20	#71046	#71040	#71044
⑤ MR M3.0x20	#73016	#73010	#73014
⑥ MR # 6-32x25	#71056	#71050	#71054
⑦ MR # 3-48x25	#72016	#72010	#72014
⑧ MR # 3-48x27	#72026	#72020	#72024
⑨ MR # 3-48x31.75	#72036	#72030	#72034
⑩ MR M3.0x26	#73026	#73020	#73024
⑪ MF # 4-40x19	N/A	#73910	N/A
⑫ MR M4.0x18	#73926	N/A	N/A
⑬ WR 3.0x25	H93086	H93080	H93084
⑭ WRP 2.5x31	H94016	H94010	H94014
⑮ WRP 2.5x35	H94036	H94030	H94034
⑯ WF 2.6x38.5	H91116	N/A	N/A
⑰ MR # 6-32x12	H80006	H80000	H80004
⑱ MO # 6-32x8	H80156	H80150	H80154
⑲ WF 2.5x10	H91056	H91050	H91054
⑳ WR 3.0x12	H93076	H93070	H93074
㉑ WF #2x12.7	H91146	H91140	H91144
㉒ WF #2x14.3	H91156	H91150	H91154
㉓ WF 2.2 #2x19	H91046	H91040	H91044



① R68-10L	#7590
② R68-15L	#7591
③ V-0.5x13L	#7500
④ V-0.7x22L	#7510
⑤ V-0.8x20L	#7520
⑥ I-0.5x31L	#7605
⑦ I-0.6x30L	#7620

Shield plate for Pickups



PB-SHIELD #5960

Wires for Pickups

Flex #22 -BK	#66215
Flex #22 -YL	#66218
Flex #22 -GR	#66214
Flex #22 -WH	#66216
Flex #22 -BL	#66213
Flex #22 -RED	#66217
Tefron #22 -RED	#66010
Push Back -BLK	#66201
Push Back -WH	#66202
Tefron 1P	#66225
Braided Shield	#66100
#28 -BLK	#66002
#28 -RED	#66001

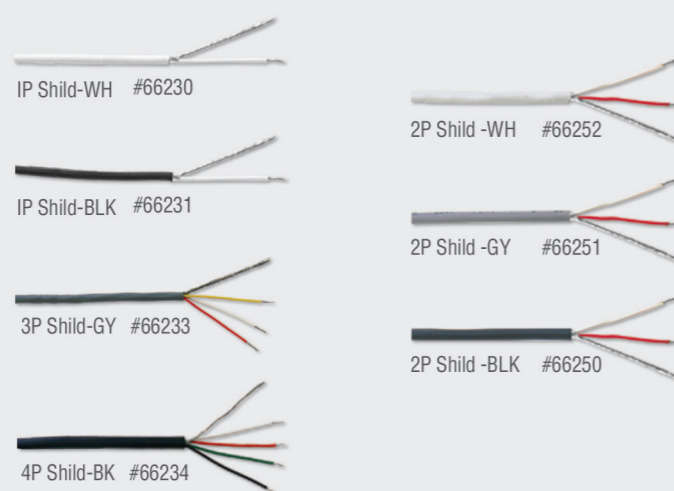

1P Shild-WH #66230

1P Shild-BLK #66231

3P Shild-GY #66233

4P Shild-BK #66234

2P Shild -WH #66252

2P Shild -GY #66251

2P Shild -BLK #66250

Sales Terms

WOOSUNG CHORUS INDUSTRIES, more commonly known as WSC has been manufacturing pickups, and various guitar parts since 1991. Our goal is to understand customer's needs and provide better quality products. We continue to look forward to working with you. Please review following information before ordering.

Inquiries

WSC wholesale pricelist is based on FOB Korea. Please contact us to request a copy of a pricelist or to place an order. Email us anytime at sales@wscmusic.com or fax us 82-32-515-7941. We will get back to you within 24 hours.

Minimum Order

Each item requires certain minimum order quantity (For more information, visit our web sites) and there is a minimum order amount (\$2,000), is limited under 20 items. However, these minimum rules are not applied to the sample orders and special cases.

Ordering

Please email or fax us the model code, model name, color, quantity and other special notes including your name, name of company, and address. Once you submit your order, we will send you a Pro-Forma invoice in a day.

Payment and Lead Time

At present payment currency is US dollars. The bank wire transfer and Paypal are acceptable for the payment. Once we receive the payment, the order begins processing and it will be shipped in 4 weeks. For the faster process, you can fax the copy of T/T application for our reference.

Shipping

Generally we ship via Air Freight. Upon customer's request, we ship via ocean or Express Courier Service such as DHL, UPS, FEDEX, and EMS (EMS is the only prepaid).

- 1) Ship via Air Freight: \$150 of handling charge when the invoice value is under \$2,000
- 2) Ship via Ocean : \$200 of trucking charge when the invoice value is under \$10,000.
- 3) Sample Sending : We usually ship via Express Courier Service with Freight Collect.

Price Changes

Due to varying manufacturing cost, the price is subject to change without prior notice.

Roswell[®]
PICKUPS
WooSung Chorus Industries

#419-5, Cheong Cheon 2 dong, Bupyeong-Gu, Incheon 21314, Korea

TEL: 82-32-515-7940 FAX: 82-32-515-7941

Web : www.roswellpickups.com

E-mail : sales@roswellpickups.com



WooSung Chorus Industries

419-5, Cheong Cheon-2dong, Bupyeong-Gu,
Incheon 21314, KOREA
Tel : (82)32-515-7940 Fax : (82)32-515-7941
www.roswellpickups.com
sales@roswellpickups.com